



MM06UE01-2306_V3.2

Assembly instructions

Linear motor axis LMSSA

LMSSA-02-1-EN-2506-MA

Imprint

HIWIN GmbH

Brücklesbünd 1

77654 Offenburg

Germany

Fon +49 781 93278-0

info@hiwin.de

www.hiwin.de

All rights reserved.

Complete or partial reproduction is not permitted without our permission.

These assembly instructions are protected by copyright. Any reproduction, publication in whole or in part, modification or abridgement requires the written approval of HIWIN GmbH.

Contents

- 1 General information 5**
 - 1.1 About this user manual.....5
 - 1.2 General Precautions.....5
 - 1.3 Safety Precautions.....5
 - 1.4 Requirements 10
 - 1.5 Copyright..... 10
 - 1.6 Manufacturer information..... 10

- 2 Basic safety notices 11**
 - 2.1 Overview 11
 - 2.2 Basic safety notices..... 11
 - 2.3 Reasonably foreseeable misuse..... 11
 - 2.4 Conversions and modifications 11
 - 2.5 Residual risks 11
 - 2.6 Personnel requirements..... 12
 - 2.7 Protective equipment 12
 - 2.8 Labels on linear motor system 13

- 3 Product description..... 14**
 - 3.1 Linear motor system description..... 14
 - 3.2 Main components of the linear motor system 15
 - 3.3 Order code 16
 - 3.4 Linear motor 17
 - 3.5 Positioning measurement system 18
 - 3.6 Limit switches (optional) 19
 - 3.7 Cable chain (optional) 19

- 4 Transport and setup 22**
 - 4.1 Delivery 22
 - 4.2 Transport to the installation site 22
 - 4.3 Requirements at the installation site 23
 - 4.4 Storage 24
 - 4.5 Unpacking and setup 24

- 5 Assembly and connection..... 25**
 - 5.1 Mechanical installation 25
 - 5.2 Electrical installation..... 29

- 6 Commissioning 37**
 - 6.1 Switch on the linear motor system 37
 - 6.2 Programming..... 38

- 7 Maintenance and cleaning 39**
 - 7.1 Maintenance..... 39

- 8 Disposal 47**
 - 8.1 Waste disposal 47

- 9 Troubleshooting 48**
 - 9.1 Troubleshooting..... 48

10	Declaration of Incorporation	49
11	Appendix.....	50
11.1	Glossary.....	50
11.2	Unit conversion.....	52
11.3	Tolerances and hypotheses	53
11.4	Supplementary formula	53
11.5	Optional accessories.....	59
11.6	Customer request form	61

1 General information

1.1 About this user manual

This manual aims to assist users to operate Single-Axis Linear Motor Stage (SSA series). The contents of this manual, including general information, basic safety information, product description, transport and setup, assembly and connection, commissioning, maintenance and cleaning, disposal, troubleshooting, declaration of incorporation and appendix, are arranged in accordance with the procedure of configuring a machine. Please read through this manual to correctly operate Single-Axis Linear Motor Stage (SSA series).

1.2 General Precautions

Before using the product, please carefully read through this manual. HIWIN is not responsible for any damage, accident or injury caused by failure in following the installation instructions and operating instructions stated in this manual.

- Before installing or using the product, ensure there is no damage on its appearance. If any damage is found after inspection, please contact HIWIN or local distributors.
- Do not disassemble or modify the product. The design of the product has been verified by structural calculation, computer simulation and actual testing. HIWIN is not responsible for any damage, accident or injury caused by disassembly or modification done by users.
- Ensure the wiring is not damaged and can be normally connected.
- Keep children away from the product.
- Anyone with psychosomatic illness or insufficient experience should not use the product alone. The supervision of managers or product docents is definitely needed.

If the login information does not match your order, please contact HIWIN or local distributors.

HIWIN offers 1-year warranty for the product. The warranty does not cover damage caused by improper usage (refer to the precautions and instructions stated in this manual) or natural disaster.

1.3 Safety Precautions

- Depictions used in this user manual:

1.3.1 Instructions:

Instructions are indicated by diamond point.

Example:

- ▶ Position the linear motor system on the mounting holes.
- ▶ Place the mounting bolts into the mounting holes and tighten in a spiral pattern to a torque of 10 Nm.

1.3.2 Lists

Lists are indicated by bullet points.

Example:

The linear motor systems must not be operated:

- ▶ Outdoors
- ▶ In potentially explosive atmospheres

1.3.3 Information

Information is to describe general information and recommendations.

Example:

Note:

Please contact HIWIN for special requests.

- Carefully read through this manual before installation, transportation, maintenance and examination. Ensure the product is correctly used.
- Carefully read through electromagnetic (EM) information, safety information and related precautions before using the product.
- Safety precautions in this manual are classified into "DANGER" , "WARNING" and "CAUTION".

 **Danger!** Imminent danger!

Indicates that death or severe personal injury will result if proper precautions are not taken.

 **Warning!** Potentially dangerous situation!







Indicates that death or severe personal injury may result if proper precautions are not taken.

 **Attention!** Potentially dangerous situation!

Indicates that property damage or environmental pollution can result if proper precautions are not taken.

1.3.4 Warning Signs

The following symbols are used in this user manual and on the linear motor system:

Warning and prohibition signs			
	No access for people with active implanted cardiac devices.		Substance hazardous to the environment!
	Warning!		Warning of crushing of hands!
	Warning of electricity!		Warning of hot surface!
	Warning of magnetic field!		

Mandatory signs			
	Wear head protection!		Wear safety footwear!
	Wear protective gloves!		Disconnect before carrying out maintenance or repair.
	Wear safety footwear!		Lifting point

○ Basic safety notices

⚠ Danger! Danger from strong magnetic fields!

Strong magnetic fields around linear motor systems pose a health risk to persons with implants (e.g. cardiac pacemakers) that are affected by magnetic fields.

- ▶ Anyone with implants that are affected by magnetic fields should maintain a safe distance of at least 500 mm from linear motor systems (trigger threshold for static magnetic fields of 0,5 mT as per directive 2013/35/EU).

⚠ Warning! Risk of Linear motor operate.

When incorrectly operated and in the case of a fault, the motor can overheat resulting in fire and smoke. This can result in severe injury or death. Further, excessively high temperatures destroy motor components and result in increased failures as well as shorter service lives of motors.

- ▶ Operate the motor according to the relevant specifications.
- ▶ Allow the forcer to cool down sufficiently (in a 25°C room temperature) before working around the product to avoid burns.
- ▶ When an abnormal smell, noise, smoke, or vibration is detected, please turn off the power immediately.

⚠ Caution! Risk of physical damage to watches and magnetic storage media.

Strong magnetic forces may destroy watches and magnetizable data storage media near to the linear motor system!

- ▶ Do not bring watches or magnetizable data storage media into the vicinity (<300 mm) of the linear motor systems!

○ Transport to the installation site

⚠ Warning! Risk of crushing from forcer housing!

Danger of injury from crushing and damage to the linear motor system caused by movement of the forcer housing due to gravity, as it does not feature brakes in its standard version. Operate the motor according to the relevant specifications.

- ▶ Ensure that each transportation safety devices are well fixed before transportation. In most cases, the devices are made in red.

⚠ Warning! Danger from heavy loads!

Lifting heavy loads may damage your health.

- ▶ For system's weight over 20 kg, use a hoist of an appropriate size when positioning heavy loads!
- ▶ Check applicable occupational health and safety regulations when handling suspended loads!

○ Assembly and connection**⚠ Danger!** Danger from electrical voltage!

Before and during assembly, disassembly and repair work, dangerous currents may flow.

- ▶ Work may only be carried out by a qualified electrician and with the power supply disconnected!
- ▶ Before carrying out work on the linear motor system, disconnect the power supply and protect it from being switched back on!

⚠ Danger! Risk of crushing from strong forces of attraction!

There is a risk of crushing from the strong forces of attraction emitted by the stators, as they are assembled with opposing polarity!

- ▶ Assemble the stators carefully!
- ▶ Do not place fingers or objects between the stators!

⚠ Warning! Risk of crushing from forcer housing!

Danger of injury from crushing and damage to the linear motor system caused by movement of the forcer housing due to gravity, as it does not feature brakes in its standard version.

- ▶ Ensure that the linear motor system does not exceed 1° horizontal deviation!

⚠ Warning! Risk of crushing from the forcer!

Danger of injury from crushing and damage to the forcer through uncontrolled movements during assembly.

- ▶ Ensure that the forcer is locked in place during assembly using transportation safety devices!

⚠ Warning! Risk of crushing from strong forces of attraction!

Danger of injury from crushing and damage to the forcer or stator caused by very strong forces of attraction.

- ▶ Ensure that the forcer only comes close to the stator when the linear guideways can absorb the forces!

⚠ Warning! Danger from heavy loads!

Lifting heavy loads may damage your health.

- ▶ Use a hoist of an appropriate size when positioning heavy loads which are over 20 kg!
- ▶ Check applicable occupational health and safety regulations when handling suspended loads!
- ▶ To transport the linear axis, hoist it at the points designated A and B!

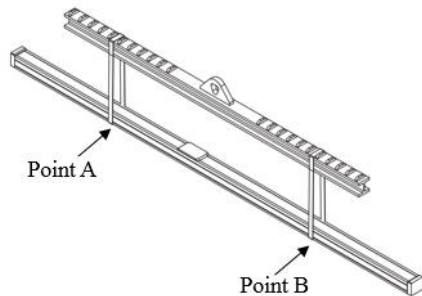

○ Electrical connection

⚠ Danger! Danger from electrical voltage!

If linear motors are incorrectly grounded, there is a danger of electric shock. Assemble the stators carefully!

- ▶ Before connecting the electrical power supply, ensure that the linear motor system is correctly grounded.

⚠ Danger! Danger from electrical voltage!

Electrical currents may flow even if the motor is not moving.

- ▶ Ensure that the linear motor system is disconnected from the power supply before the electrical connections are detached from the motors.
- ▶ After disconnecting the drive amplifier from the power supply, wait at least 5 minutes before touching live parts or breaking connections.
- ▶ For safety reasons, measure the voltage in the intermediate circuit and wait until it has fallen below 40 V.

○ Switch on the linear motor system

⚠ Warning! Risk of crushing from strong forces of attraction!

Strong magnetic forces may attract steel or iron objects from the linear motor system and cause crushing!

- ▶ No heavy (> 1 kg) or large (> 0,01 m²) steel or iron objects should be introduced by hand into the immediate surrounding area (50 mm) of the magnet track!
- ▶ Use suitable tools only.

⚠ Warning! Risk of crushing from moving forcer housing!

The forcer housing may cause damage to parts through its movement at the end position of the machine.

- ▶ The operator should provide protective equipment to prevent from reaching into the danger area of the machine!

⚠ Warning! Risk of burns!

The motor heats up during operation and thus touching the motor can lead to burns!

- ▶ Provide protective devices and warning notices at the motor!

- Maintenance and cleaning

⚠ Danger! Danger from electrical voltage!

Before and during maintenance and cleaning, dangerous currents may flow.

- ▶ Work may only be carried out by a qualified electrician and with the power supply disconnected!
- ▶ Before carrying out work on the linear motor system, disconnect the power supply and protect it from being switched back on!

⚠ Warning! Risk of crushing from moving parts!

The forcer housing may cause damage to parts through its movement at the end position of the machine.

- ▶ The operator should provide protective equipment to prevent from reaching into the danger area of the machine!

⚠ Warning! Risk of burns!

The motor heats up during operation and thus touching the motor can lead to burns!

- ▶ After disconnecting the drive amplifier from the power supply, wait at least 5 minutes before removing the cover and touching the motor.

⚠ Warning! Unauthorized repairs on the system

- ▶ Unauthorized work on the system creates the risk of injuries and may invalidate the warranty.
- ▶ The system must only be serviced by specialist personnel!

1.4 Requirements

We assume that

- operating staff are trained in the safe operation practices for linear motor systems and have read and understood this user manual in full;
- maintenance staff maintain and repair the linear motor systems in such a way that they pose no danger to people, property or the environment.

1.5 Copyright

This user manual is protected by copyright. Any reproduction, publication in whole or in part, modification or abridgement requires the written approval of HIWIN GmbH.

1.6 Manufacturer information

Address	HIWIN GmbH Brücklesbünd 1 77654 Offenburg Germany
Phone	+49 (0) 781 932 78-0
Technical customer service	+49 (0) 781 / 9 32 78 - 77
Fax	+49 (0) 781 932 78-90
Technical customer service fax	+49 (0) 781 / 9 32 78 - 97
E-mail	support@hiwin.de
Website	www.hiwin.de

2 Basic safety notices

2.1 Overview

The linear motor system is a linear drive and guiding system for the precise positioning of fixed mounted loads, e.g. system components within an automated system, in terms of time and location.

The LMSSA linear motor systems are designed for installation and operation in horizontal plane and therefore do not feature parking brakes in their standard versions. In the case of vertical assembly, a parking brake, weight compensation device or both must be retrofitted. The loads to be moved must either be mounted on to the forcer or the base. The linear axes can be mounted on top of one another to create multi-axis systems.

2.2 Basic safety notices

The specified linear motor systems may not be used outdoors or in hazardous areas where there is a risk of explosions. All linear motor systems may only be used for the stated intended purpose.

- The linear motor system must be operated within its specified performance limits (see technical information and the approval drawing).
- Reading through the user manual and compliance with the maintenance and repair regulations are necessary for the intended use of the linear motor systems.
- Any other use of the linear motor system shall be considered as contrary to the intended use.
- Use only original spare parts from HIWIN.

2.3 Reasonably foreseeable misuse

The linear motor systems must not be operated:

- Outdoors
- In potentially explosive atmospheres

2.4 Conversions and modifications

Modifications of the linear motor systems are not permitted! Please contact HIWIN for special request.

2.5 Residual risks

Normal operation of the linear motor systems constitutes no residual risks.

Warnings about risks that may arise during maintenance and repair work are provided in the relevant sections.

2.6 Personnel requirements

Only authorized persons may carry out work on the linear motor systems! They must be familiar with the safety equipment and regulations before starting work (See **Fehler! Verweisquelle konnte nicht gefunden werden.**).

Table 2.1:

Activity	Qualification
Normal operation	Trained personnel
Cleaning	Trained personnel
Maintenance	Trained specialist personnel of the operator or manufacturer
Repairs	Trained specialist personnel of the operator or manufacturer

2.7 Protective equipment

2.7.1 Personal protective equipment

⚠ Caution! Risk of noise.

The information below will enable the user of the machine to make a better evaluation of the hazard and risk.

- ▶ Equivalent A-weighted Sound pressure level according to EN ISO 3746: 70,5 dB (A)
- ▶ Uncertainty, K in decibels: 4,0 dB (A) according to EN ISO 4871

The emission levels are not necessarily safe working levels. While there is a correlation between the emission and exposure levels, this cannot be used reliably to determine whether or not further precautions are required.

Factors that influence the actual level of exposure of the workforce include the characteristics of the work room, the other sources of noise, the number of machines, other adjacent processes, and the length of time for which an operator is exposed to the noise. Also, the permissible exposure level can vary from country to country.

Table 2.2: Personnel requirements

Operating phase	Personal protective equipment
Normal operation	When in the vicinity of the linear motor systems, the following personal protective equipment is required: <ul style="list-style-type: none"> ○ Safety shoes ○ Protective helmet ○ Protective gloves
Cleaning	When cleaning the linear motor systems, the following personal protective equipment is required: <ul style="list-style-type: none"> ○ Safety shoes ○ Protective helmet ○ Protective gloves
Maintenance and repairs	When carrying out maintenance and repairs of the Single-Axis Linear Motor Stage, the following personal protective equipment is required: <ul style="list-style-type: none"> ○ Safety shoes ○ Protective helmet ○ Protective gloves

2.7.2 Protective equipment on the linear motor system

Linear motor systems are fitted with position dampers.

- After every maintenance and repairs, these position dampers must be tested at the end positions and, if necessary, replaced.

The machine may not be operated without position dampers or when dampers are damaged!

2.8 Labels on linear motor system

Fig. 2.1: Warning symbols and plate – here for a LMSSA linear motor system

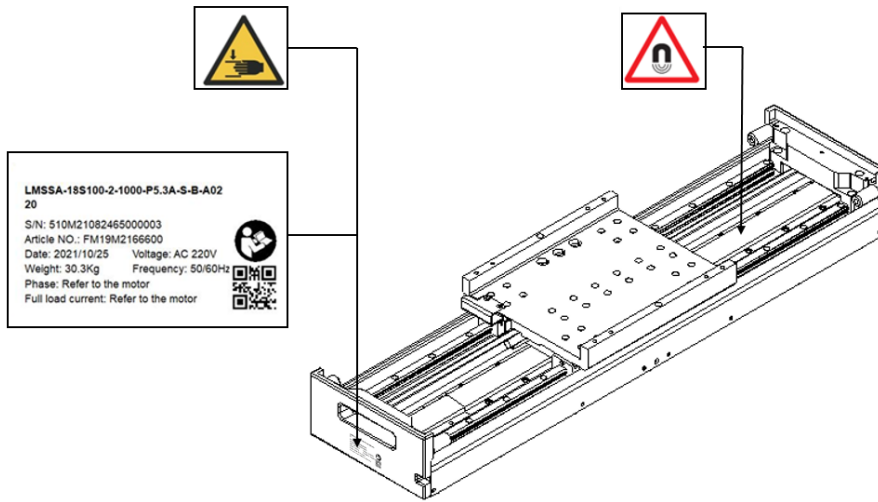



Table 2.3: Warning symbols

Pictogramm	Type and source of danger	Protective measures
	Danger from movements!	Keep out of the machine's area of movements! Prevent unauthorized access to the danger area!
	Danger from strong magnetic fields!	Anyone whose health may be endangered by strong magnetic fields must keep a safe distance (0,5 m) from the linear motor system!

3 Product description

3.1 Linear motor system description

A linear motor system comprises a base with integrated linear guideways. They absorb the forces exerted by the weights, accelerations, and processes and provide precise guiding for the forcer housing. The system is driven by iron-core or ironless linear motors manufactured by HIWIN.

Table 3.1: LMSSA Series Stage shows the family of a LMSSA Series Stage. Standard design of LMSSA also includes an integral top cover, seals, a high accuracy non-contact linear encoder. Limit switches and stopper, which protect the carriage from overtraveling. The LMSSA series stages have travel distances ranging from 100 to 2700 mm. It can be used in industries covering automation, laser processing, semiconductors, etc. The linear motor system is used for movement of fixed mounted loads on the forcer housing. These LMSSA models are usually mounted and operated horizontally. In case of vertical applications, please contact HIWIN for weight compensation calculations.

Table 3.1: LMSSA Series Stage

Type	Standard	Dust-proof	Clean room
08			
10			
13			
18			-
20			

Note:

HIWIN continually improves its product offerings, and listed options may be replaced at any time. Please refer to the most recent edition HIWIN of the product guide for the latest product information at www.hiwin.de.

3.2 Main components of the linear motor system

Fig. 3.1: Main components of the linear motor system – here for a LMSSA linear motor system

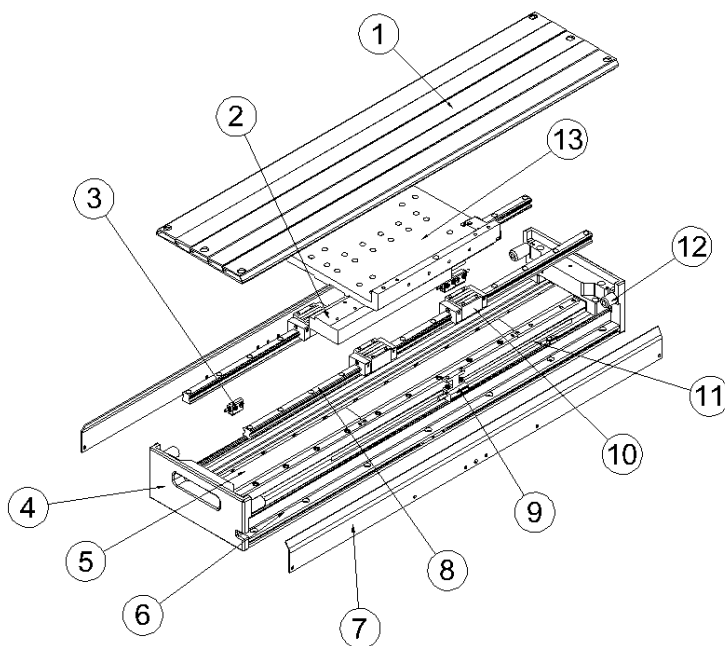

Table 3.2: Main components of the linear motor system

Pos.	Components	Pos.	Components
1	Top Cover	8	Linear guideway
2	Forcer (primary part)	9	Encoder with mounting bracket
3	Reference and limit switches with mounting bracket	10	Linear guideway block
4	End plate	11	Scale
5	Stator (secondary part of the linear motor)	12	Position damper
6	Base	13	Forcer housing
7	Side Cover		

3.3 Order code

Number	1	2	3	4	5	6	7
Order code	LMSSA	13	S	100	1	800	G
1	LMSSA	Linear motor axis					
2	13	Width [mm]: 08: 80 10: 100 13: 135 18: 185 20: 206					
3	S	Motor type: S: Iron core C: Ironless					
4	100	Rated force level ¹⁾ : 050, 100, 200, 300, 500, 700					
5	1	Number of forcers: 1: Single forcer 2: Dual forcers					
6	800	Stroke [mm]: 100 - 2.700 (Available in 50 mm increment up to 1.300 mm and 100 mm increments up to 2.700 mm)					
7	G	Encoder type: A: Analog optical D: Analog magnetic E: Digital 1 µm resolution magnetic encoder G: Digital 1 µm resolution optical encoder K: Digital 0,1 µm resolution optical encoder H: Hall encoder (Analog) P: Absolut optical encoder 0,5 µm (BiSS-C)					

Number	8	9	10	11	12	13
Order code	5.3	A	S	S	A	0000
8	5.3	Cable length ^{2), 3)} : 3.3: Power: 3 m/Encoder: 3 m (For SSA-08, 10) 5.3: Power: 5 m/Encoder: 3 m 7.3: Power: 7 m/Encoder: 3 m (For SSA-13, 18, 20)				
9	A	Limit switch: A: NPN.NC B: PNP.NC				
10	S	Cover: S: Standard M: Dust-proof P: Clean room				
11	S	Colour: S: Aluminium colour (For SSA-18, 20) B: Black				
12	A	Voltage: A: Standard B: High voltage (For SSA S cover: SSA-18, 20 M cover)				
13	0000	Custom code: 0000: Standard				

¹⁾ Please refer to the [Table 3.3](#) and [Table 3.4](#).

²⁾ Encoder extension cable is sold separately (see page 59).

³⁾ The length of cable is measured from the motor/encoder.

The length from the forcer plate will be 0,5 m shorter. For example, if the distance from the motor/encoder is 3 m, the distance from the forcer plate is 2,5 m.

Note:

HIWIN continually improves its product offerings, and listed options may be replaced at any time. Please refer to the most recent edition of the product guide for the latest product information at www.hiwin.de.

3.4 Linear motor

A linear motor consists of two components, the forcer (primary part) with coils and the stator (secondary part) with permanent magnets. The coils carrying alternating current generate a magnetic field that changes over time and interacts with the steady magnetic field of the stator. The resulting force is used to generate linear motion. The linear motor components are supplied as separate parts.

Table 3.3: Linear motor type (for SSA-08/10/13)

	Symbol	Unit	08S050	08S100	10S100	10S200	13S100	13S200	13S300
Continuous force	F_c	N	52	104	103	205	103	205	308
Continuous current	I_c	A_{rms}	2,1	4,2	2,1	4,2	2,1	4,2	6,3
Peak force (1s)	F_p	N	112	224	289	579	289	579	868
Peak current (1s)	I_p	A_{rms}	6,3	12,6	6,3	12,7	6,3	12,7	19,0
Attraction force	F_a	N	241	482	481	963	481	963	1.444
Resistance (line to line, 25°C)	R_{25}	Ω	6,2	3,1	8,4	4,1	8,4	4,1	2,8
Resistance (line to line, 120°C)	R_{120}	Ω	8,5	4,3	11,6	5,7	11,6	5,7	3,9
Inductance (line to line)	L	mH	23	11,6	37,1	18,5	37,1	18,5	12,4
Pole pair pitch	2 τ	mm	30						
Thermal switch	-	-	3PTC SNM120 In Series (for high voltage)						
Maximum DC bus voltage	-	V_{DC}	500 / 600 (for high voltage)						

Table 3.4: Linear motor type (for SSA-18/20)

	Symbol	Unit	18S 100	18S 200	18S 300	18C 100	18C 200	20S 300	20S 500	20S 700	20C 100	20C 200
Continuous force	F_c	N	103	205	308	75	150	362	544	725	91	145
Continuous current	I_c	A_{rms}	2,1	4,2	6,3	3,4	3,4	3,9	5,9	7,8	2,0	2,0
Peak force (1s)	F_p	N	289	579	868	300	600	1.023	1.535	2.048	364	580
Peak current (1s)	I_p	A_{rms}	6,3	12,7	19,0	13,6	13,6	11,8	17,6	23,5	8,0	8,0
Attraction force	F_a	N	481	963	1.444	-	-	1.926	2.888	3.851	-	-
Resistance (line to line, 25°C)	R_{25}	Ω	8,4	4,1	2,8	3,3	6,3	6,8	4,6	3,5	9,0	14,6
Resistance (line to line, 120°C)	R_{120}	Ω	11,6	5,7	3,9	-	-	9,4	6,3	4,8	-	-
Inductance (line to line)	L	mH	37,1	18,5	12,4	2,3	4,5	33,0	22,4	16,0	3,2	5,0
Pole pair pitch	2 τ	mm	30			60		30			32	
Thermal switch	-	-	3PTC SNM120 In Series (for high voltage)			PTC		3PTC SNM120 In Series (for high voltage)			PTC	
Maximum DC bus voltage	-	V_{DC}	500 / 600 (for high voltage)			330		500 / 600 (for high voltage)			330	

3.5 Positioning measurement system

⚠ Caution! Damage caused by scratching!

The measuring scale of the optical measuring system may be damaged by improper handling. Equivalent A-weighted Sound pressure level according to EN ISO 3746: 70,5 dB (A)

► Handle the measuring scale with care!

⚠ Caution! Damage to the magnetic positioning measurement system!

Strong magnetic fields and vibrations can damage the magnetic positioning measurement system.

- ▶ Protect the magnetic positioning measurement system against strong magnetic fields!
- ▶ Protect the magnetic positioning measurement system against strong vibrations!

The distance travelled is measured by a high-resolution positioning measurement system that is mounted on the base. Depending on its type, the linear motor system features an optical or a magnetic positioning measurement system. The installed positioning measurement system is fully cabled and is connected to the controller via a separate connector (see technical Information and approval drawing).

Table 3.1: Positioning measurement system selection

Order code	Power supply		Resolution[μm]	Interface	
	V	mA			
A	5V (-5%/+10%)	150 mA (fully terminated)	0,1 (suggested value)	Incremental	1 Vpp (analog)
D	5V (±5%)	30 mA (fully terminated)	1 (suggested value)	Incremental	1 Vpp (analog)
E	5V (±5%)	20 mA (fully terminated)	1	Incremental	TTL (digital)
G	5V (-5%/+10%)	200 mA (fully terminated)	1	Incremental	TTL (digital)
K	5V (-5%/+10%)	200 mA (fully terminated)	0,1	Incremental	TTL (digital)
H	5V (±5%)	40 mA (fully terminated)	2 (suggested value)	Incremental	1 Vpp (analog)
P	5V (±10%)	250 mA (fully terminated)	0,5	Absolute, 26-bit	BiSS-C

3.6 Limit switches (optional)

Depending on the type, a few optical or inductive switches generate a signal to the controller upon reaching the end of the travel distance. The limit switches are supplied pre-wired and operational.

Fig. 3.2: pin assignment (standard)

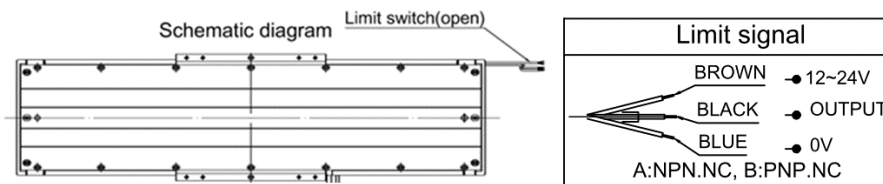

3.7 Cable chain (optional)

Table 3.2 and Table 3.3 show information of motor and encoder cable. Customers design cable chain by information on cable. Products can be customized to meet the cable chain. If a customer need cable chain by HIWIN design, please contact support@hiwin.de.

Table 3.2: Information of motor cable

Order code	Voltage	Weight (g/m)	Outer diameter (mm)	Bend radius (moved) (mm)	Bend radius (fixed) (mm)
08S050	Standard	71	6,2	47	25
	High voltage	140	9,2	69	37
08S100	Standard	71	6,2	47	25
	High voltage	140	9,2	69	37
10S100	Standard	71	6,2	47	25
	High voltage	140	9,2	69	37
10S200	Standard	71	6,2	47	25
	High voltage	140	9,2	69	37
13S100	Standard	79	7,5	38	23
	High voltage	140	9,2	69	37
13S200	Standard	79	7,5	38	23
	High voltage	140	9,2	69	37
13S300	Standard	79	7,5	38	23
	High voltage	140	9,2	69	37
18S100	Standard	79	7,5	38	23
	High voltage	140	9,2	69	37
18S200	Standard	79	7,5	38	23
	High voltage	140	9,2	69	37
18S300	Standard	79	7,5	38	23
	High voltage	140	9,2	69	37
18C100	Standard	71	6,2	47	25
18C200	Standard				
	Standard	46	7,5	38	23
	High voltage	140	9,2	69	37
	Standard	46	7,5	38	23
	High voltage	140	9,2	69	37
	Standard	79	7,5	38	23
	High voltage	140	9,2	69	37
20C100	Standard	79	7,5	38	23
20C200	Standard	79	7,5	38	23

Table 3.3: Information of motor cable

Encoder code	Weight (g/m)	Outer diameter (mm)	Bend radius (moved) (mm)	Bend radius (fixed) (mm)
A	26	4,25	30	10
D	26	5	38	20
E	26	5	38	20
G	26	4,25	30	10
K	26	4,25	30	10
H	26	5	38	20
P	32	4,7	20	10

4 Transport and setup

4.1 Delivery

The linear motor systems are supplied fully assembled, function tested and ready for connection. To prevent damage arising during transport, the linear motor systems are provided with transportation safety devices and shipping devices.

4.2 Transport to the installation site

⚠ Danger! Danger from strong magnetic fields!

Strong magnetic fields around linear motor systems pose a health risk to a person with implants (e.g. cardiac pacemakers) that are affected by magnetic fields.

- ▶ Anyone with implants that are affected by magnetic fields should maintain a safe distance of at least 500 mm from linear motor systems (trigger threshold for static magnetic fields of 0,5 mT as per directive 2013/35/EU).

⚠ Warning! Risk of crushing from forcer housing!

Danger of injury from crushing and damage to the linear motor system caused by movement of the forcer housing due to gravity, as it does not feature brakes in its standard version. The operator should provide protective equipment to prevent from reaching into the danger area of the machine!

- ▶ Ensure that each transportation safety devices are well fixed before transportation. In most cases, the devices are made in red.

⚠ Warning! Danger from heavy loads!

Lifting heavy loads may damage your health. Ensure that each transportation safety devices are well fixed before transportation. In most cases, the devices are made in red.

- ▶ For system's weight over 20 kg, use a hoist of an appropriate size when positioning heavy loads!
- ▶ Check applicable occupational health and safety regulations when handling suspended loads!

⚠ Caution! Risk of physical damage to watches and magnetic storage media.

Strong magnetic forces may destroy watches and magnetizable data storage media near to the linear motor system!

- ▶ Do not bring watches or magnetizable data storage media into the vicinity (< 300 mm) of the linear motor systems!

⚠ Caution! Damage of the linear motor system!

The linear motor system may be damaged by mechanical loading.

- ▶ No heavy load on the cover!
- ▶ Lift the linear motor system using the shipping devices (Fig. 4.1)!
- ▶ For longer linear motor system, provide additional protection of the center section.
- ▶ Ensure that the linear motor system does not bend as this could permanently damage accuracy.
- ▶ During transport, do not transport any additional loads on the linear motor system!
- ▶ Secure the linear motor system and components against tilting!

Note:

Electrical equipment is designed to withstand to protect against the effects of transportation, and storage temperature within a range of -25°C to +55°C and for short periods not exceeding 24 hours at up to +70°C.

Steps to transport the linear motor system:

- ▶ Disconnect power supply.
- ▶ Disconnect stage cables.
- ▶ Remove the payload.
- ▶ To transport the linear axis, hoist it at the points designated A and B (Fig. 4.1).
- ▶ Ensure even load distribution while lifting.

Fig. 4.1: Hoisting and transporting – here for a linear motor system

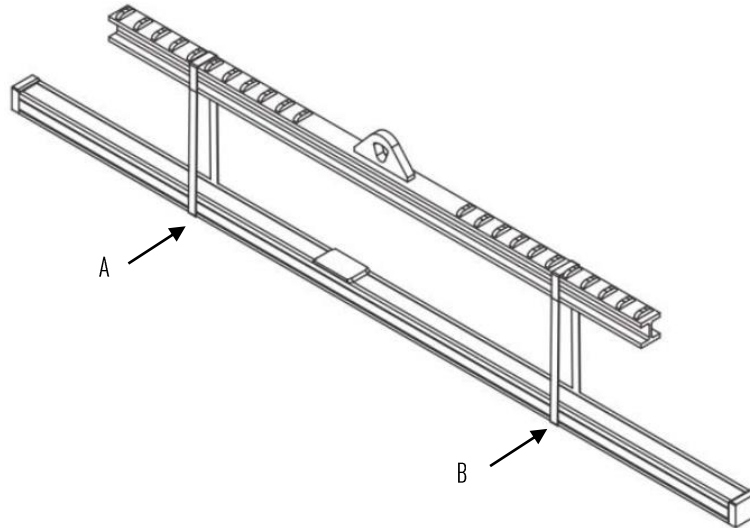
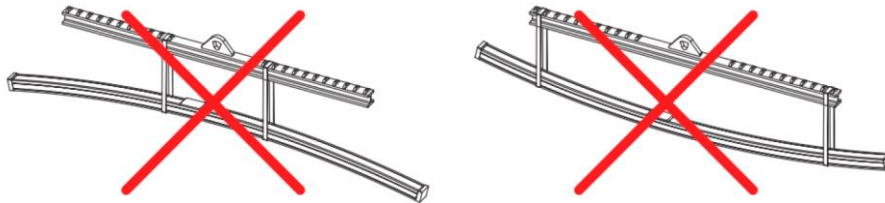

Fig. 4.2: Hoisting and transporting – Incorrect position of the supporting points



4.3 Requirements at the installation site

4.3.1 Ambient conditions

Area of use	For indoor use only
Temperature	0 °C – 50 °C
Humidity	< 80 % RH (non-condensing)
Altitude	< 1000 m
Installation site	Flat, dry, vibration-free
Protection class	No interference from corrosive solvent or strong magnetic
Grounding	Plant power grounding line conforms to international requirements

Note:

- Avoid exposing to direct sunlight or heat rays.
- Away from electric magnetic interference source sites, such as welding, discharge machine.

4.3.2 Safety equipment to be provided by the operator

Possible safety equipment/measures:

- Personal protective equipment in accordance with regional regulations
- Zero-contact protective equipment
- Mechanical protective equipment

4.4 Storage

⚠ Danger! Danger from strong magnetic fields!

Strong magnetic fields around linear motor systems pose a health risk to a person with implants (e.g. cardiac pacemakers) that are affected by magnetic fields.

- ▶ Anyone with implants that are affected by magnetic fields should maintain a safe distance of at least 500 mm from linear motor systems (trigger threshold for static magnetic fields of 0,5 mT as per directive 2013/35/EU).

Note:

- Store the linear motor system in its transport packaging.
- Only store the linear motor system in dry, frost-free areas with a corrosion-free atmosphere.
- Clean and protect used linear motor system before storage.
- When storing the linear motor system, attach signs warning of magnetic fields.

4.5 Unpacking and setup

⚠ Caution! Damage of attachments!

Attachments may be damaged by mechanical loading.

- ▶ Secure and move the linear motor system using the suspension points provided!

Note:

- The linear motor system may only be installed and operated indoors.
- The linear motor system is designed exclusively for horizontal installation. During installation, the linear motor system must not exceed an angle of 1° as it does not feature a parking brake.

Steps to unpack and install the linear motor system:

- Remove protective film.
- Carefully transport the linear motor system on the shipping devices provided to the specified installation site.
- Ensure that the maintenance points are easily accessible.
- Dispose of packaging in an environmentally friendly way.

5 Assembly and connection

5.1 Mechanical installation

5.1.1 Mechanical mounting

Fig. 5.1: LMSSA stage assembly

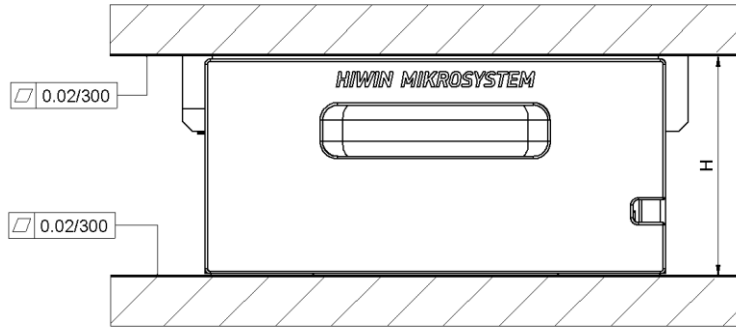

Note:

- To maintain accuracy, the mounting surface should be flat.
- The stage base is precision machined and verified for flatness prior to stage assembly at the factory.
- The accuracy is measured on granite plane before shipment.

Table 5.1: LMSSA assembly dimensions (H)

Suitable for linear axis	Dimensions(mm)		
	S Cover	M Cover	P Cover
SSA-08	75 ±0,3	78 ±0,3	82 ±0,3
SSA-10	76 ±0,3	78 ±0,3	82 ±0,3
SSA-13	95 ±0,3	98 ±0,3	100 ±0,3
SSA-18	88,7 ±0,3 / 108,7 ±0,3	93,7 ±0,3	–
SSA-20	91,7 ±0,3 / 111,7 ±0,3	94,7 ±0,3	–

5.1.2 Assembling the linear motor system

The steps for the assembling of the linear motor:

- ▶ Remove the shipping devices.
- ▶ Remove the transportation safety device from the forcer housing.
- ▶ Remove the cover or bellows if the mounting holes are inaccessible.
- ▶ Drill mounting holes in the mounting surface in accordance with scale drawing (see Technical Information and Approval Drawing).
- ▶ Clean mounting surface.
- ▶ Place the mounting bolts in the mounting holes and tighten them in a spiral motion from inside to outside with applied torque (See [Table 5.2](#)).
- ▶ If the cover or bellows were removed, install them back.

Note:

- Secure the screws with retaining rings to prevent them from accidentally coming loose!
- After assembling the moved load, please design another transportation safety device to lock the forcer housing in place during transport.
- Do not press the stainless steel sheet directly with hands (See Fig. 5.2).
- For clean room type (SSA-08/10/13), the particles from entering the slider and damage the sheet or cause the sheet to deform, lift or present other problems. This condition needs to be avoided.

Fig. 5.2: Assembling the linear motor system – here for LMSSA-08/10/13 standard type linear motor stages

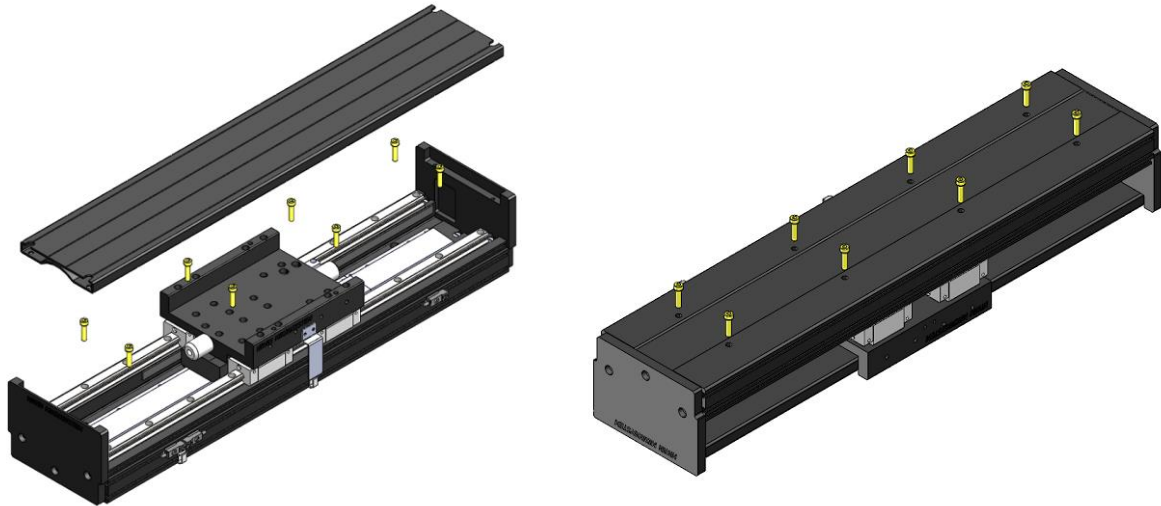

Fig. 5.3: Assembling the linear motor system – here for LMSSA-08/10/13 Dust-proof type linear motor stages

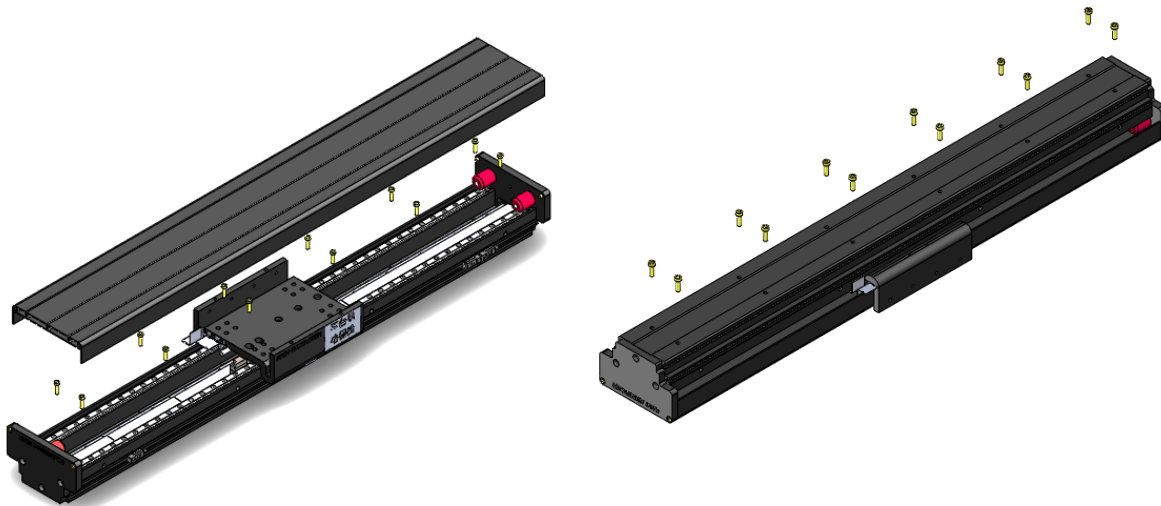

Fig. 5.4: Assembling the linear motor system – here for LMSSA-08/10/13 clear room type linear motor stages

(Fixing clamp need to be purchased additionally)

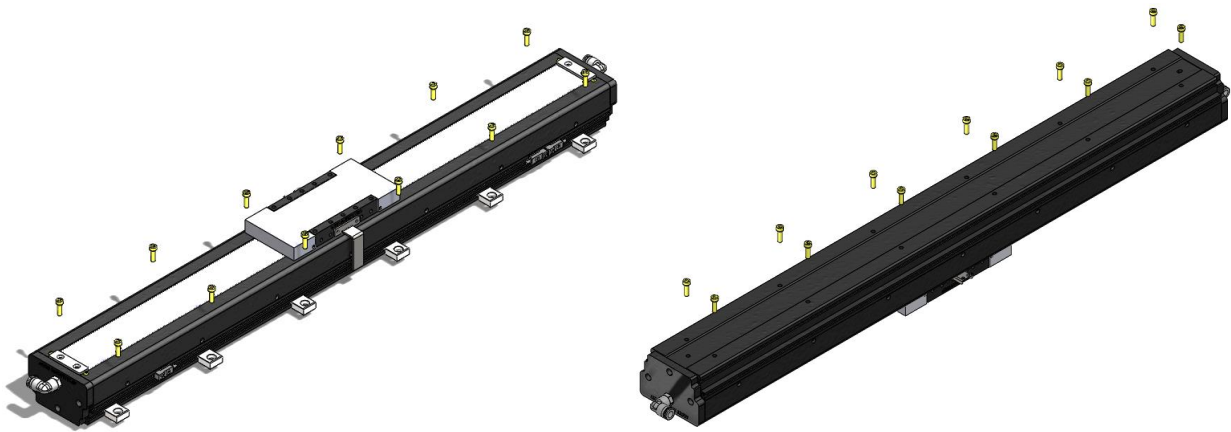

Fig. 5.5: Assembling the linear motor system – here for LMSSA-18/20 standard type linear motor stages

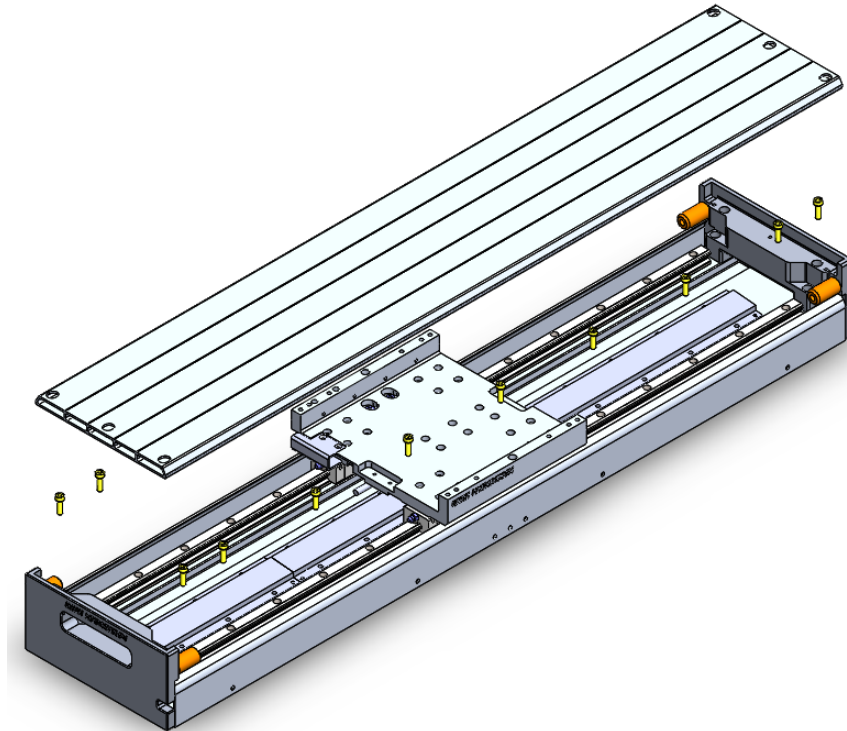

Fig. 5.6: Assembling the linear motor system – here for LMSSA-18/20 Dust-proof type linear motor stages

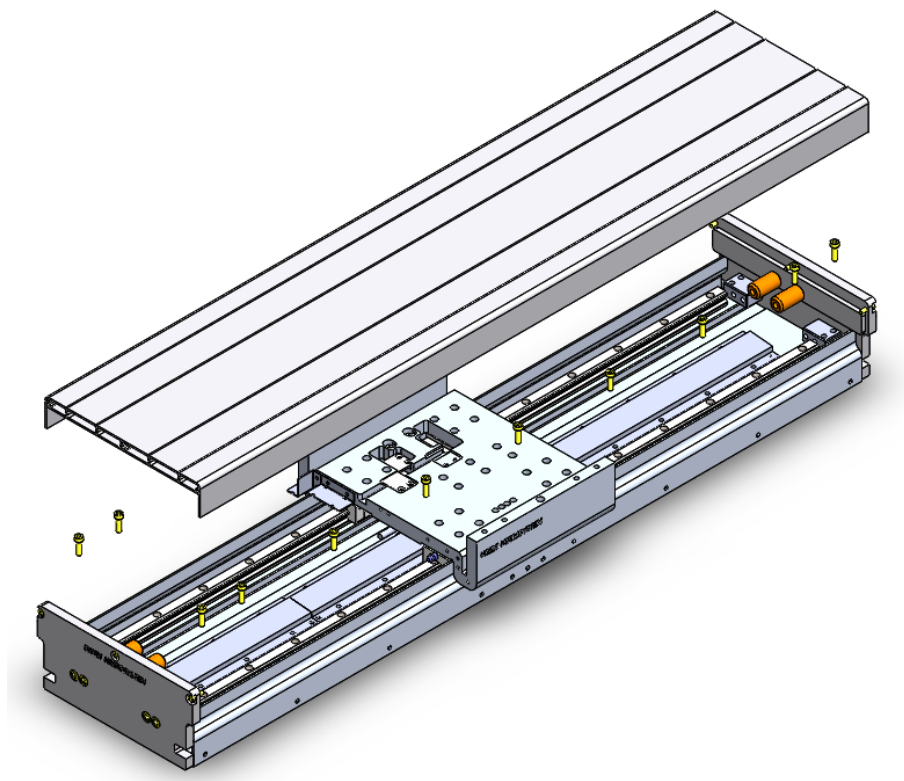

Table 5.2: Mounting torque

Suitable for linear axis	Mounting	Screw Size	Torque (Nm)
SSA-08	top	M4	3,9
SSA-10	bottom	M5	8,8
SSA-13	top	M5	8,8
	bottom	M6	11,7
SSA-18	top	M5	8,8
SSA-20	top	M5	8,8

Fig. 5.7: Do not press the stainless steel sheet – here for LMSSA-08/10/13 clear room type linear motor stages



5.1.3 Assembling the moved load

Steps to assemble the moved load:

- ▶ Clean the mounting surface on the linear motor system that is to receive the load.
- ▶ Clean the mounting surface of the load.
- ▶ Position the load over the corresponding mounting holes on the mounting surface (see technical information and approval drawing).
- ▶ Place the mounting bolts in the mounting holes and tighten them in a spiral motion from inside to outside with a torque screws (See [Table 5.2](#)).
- ▶ Check the free movement of the load over the entire travel distance.

Note:

After assembling the moved load, please design another transportation safety device to lock the forcer housing in place during transport.

5.2 Electrical installation

⚠ Danger! Danger from electrical voltage!

If linear motors are incorrectly grounded, there is a danger of electric shock.

- ▶ Before connecting the electrical power supply, ensure that the linear motor system is correctly grounded.

⚠ Danger! Danger from electrical voltage!

Electrical currents may flow even if the motor is not moving..

- ▶ Ensure that the linear motor system is disconnected from the power supply before the electrical connections are separated from the motors.
- ▶ After disconnecting the drive amplifier from the power supply, wait at least 5 minutes before touching live parts or breaking connections.
- ▶ For safety reasons, measure the voltage in the intermediate circuit and wait until it has fallen below 40 V.

Note:

- Observe the separate assembly instructions of the drive!
- The supply voltage is based on the drive. Please consult the manufacturer's separate operating instructions for detailed information.
- Supplied with cabling ready for operation.
- All necessary connections via three connectors of each axis.

Fig. 5.8: Electrical connection for D1 drive

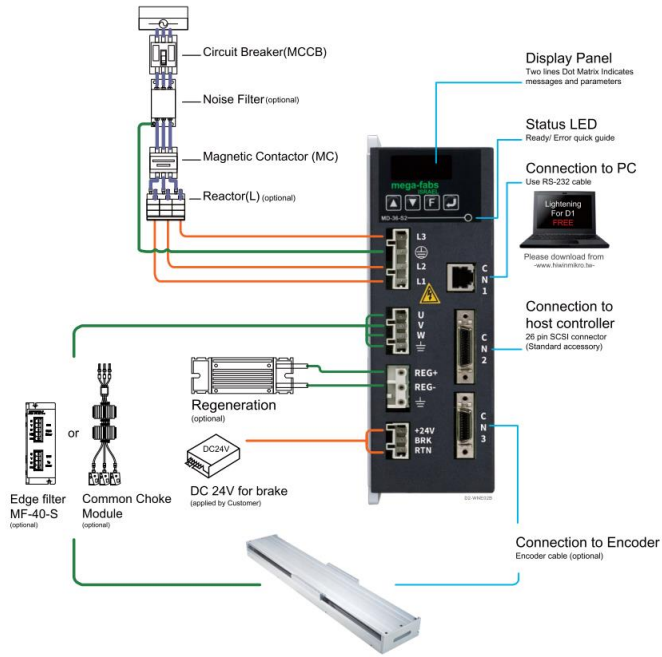

Fig. 5.9: Electrical connection for D2T-LM drive

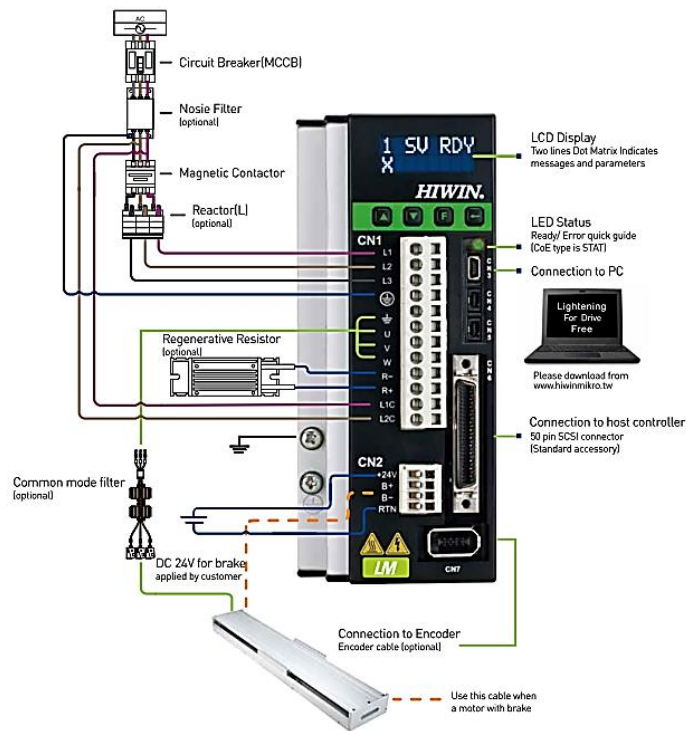
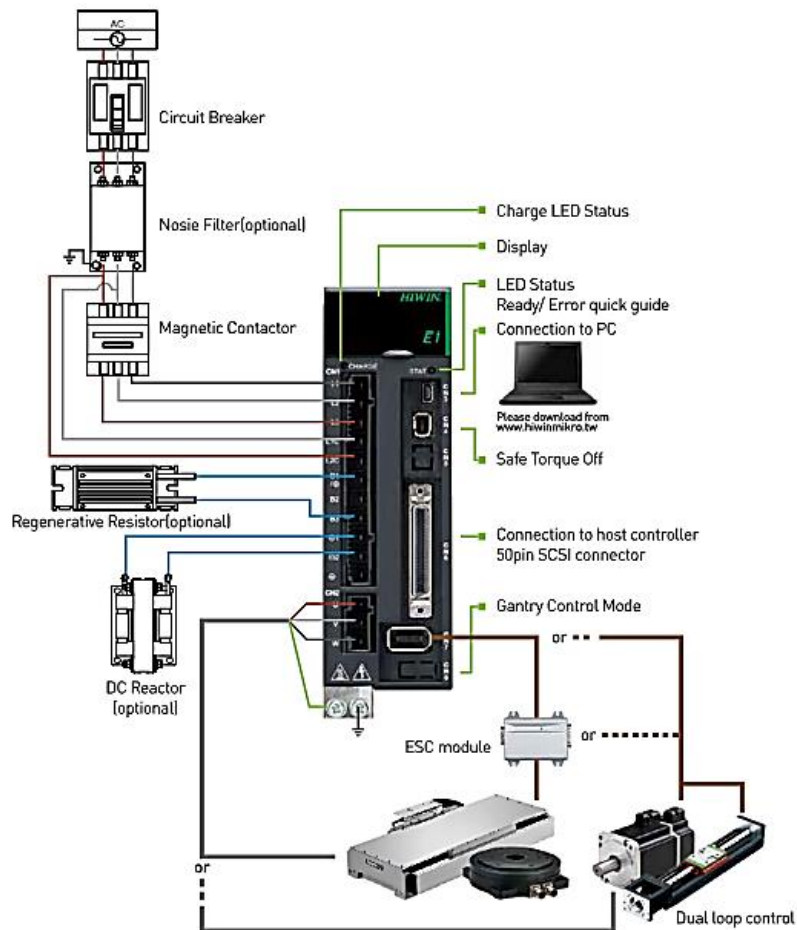

Fig. 5.10: Electrical connection for E1 drive



5.2.1 Power supply and controller selection

The continuous current, peak current and bus voltage must be considered while selecting a power supply. In addition, the resonance effect which can be induced in motors by some drive systems must be taken into account. Motors are assembled with several individual coils connected in series. Each one of these coils has an inductance in series and a stray capacitance to the ground. The LC network obtained possesses a resonant frequency, so when an electrical oscillation is applied to the phase inputs (in particular the PWM frequency), the neutral point of the motor can oscillate with very high amplitudes with respect to the ground, and the insulation can be damaged as a consequence of these oscillations. This phenomenon is more obvious in motors with a large number of poles (such as Linear motors).

When selecting power supply, please check the conditions below:

- 330 V DC controller: peak voltages < 750 V p (phase to ground), voltage gradient < 8 kV/μs.
(Table 5.3 & Fig. 5.13)
- 600 or 750 V DC controller: peak voltages < 1000 V p (phase to ground), voltage gradient < 11 kV/μs.
(Table 5.4 & Fig. 5.14)

The cable between the controller and the motor will generate a reflected wave due to the impedance mismatch between the cable and the motor, and the reflected voltage will be superimposed with the subsequent input voltage, causing the voltage to rise. This phenomenon will be more obvious when the motor cable is longer. If the length of the cable between the controller and the motor is longer than 10 m, it is necessary to measure voltages at the motor terminals to ensure they are lower than specified above. If the measured value is greater, a dV/dt filter must be inserted between the controller and the motor for protection.

Note:

- For the maximum motor operation voltage, please refer to “Linear Motor Technical Information”, which can be downloaded from the official website.
- Peak voltages and dV/dt gradients generated by the power supply must not exceed the values below (as well as neutral point):

Fig. 5.11: Voltage schematic

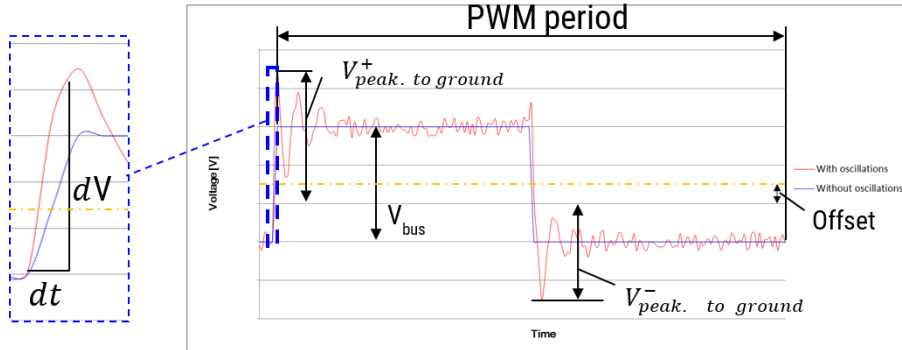

Fig. 5.12: Rising time t_r definition

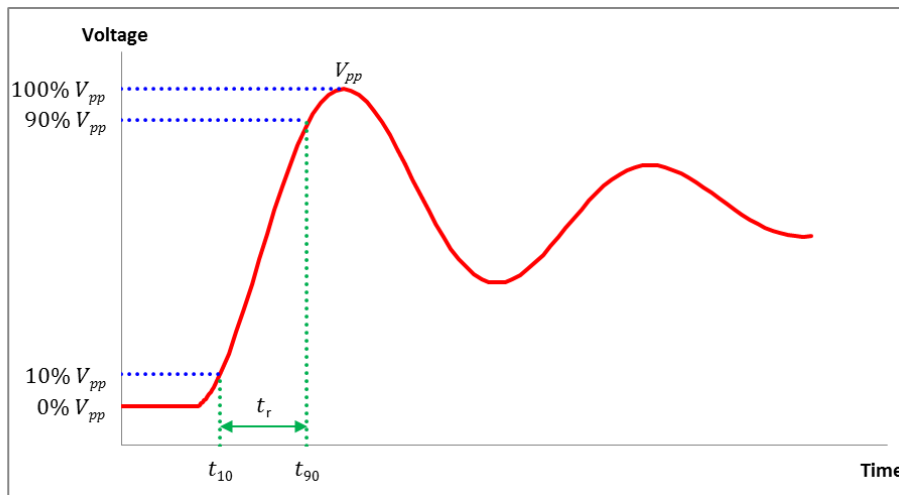

Table 5.3: 08S/10S/13S/18S/18C/20S/20C (A: Standard) series voltage limitation of power supply and neutral point

Item	Mounting
V_{bus}	Max. 330
$ V_{peak+ \text{ to ground}} $	< 750 V_p (phase to ground) @ PWM frequency
$ V_{peak- \text{ to ground}} $	< 750 V_p (phase to ground) @ PWM frequency
Voltage gradient $ dV/dt $	< 8kV/ μ s (instantaneous) If it is difficult to obtain instantaneous voltage gradient, the following formula can be used to estimate (Fig. 5.12): $ dV/dt = (90\%V_{pp} - 10\%V_p)/t_r $

Fig. 5.13: Voltage oscillation schematic (300 V_DC controller)

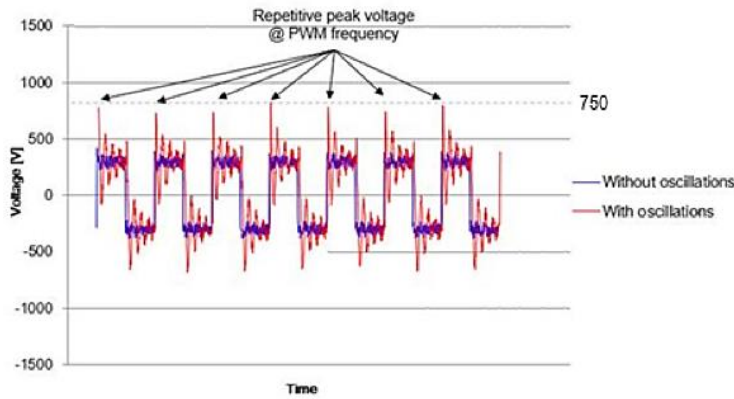
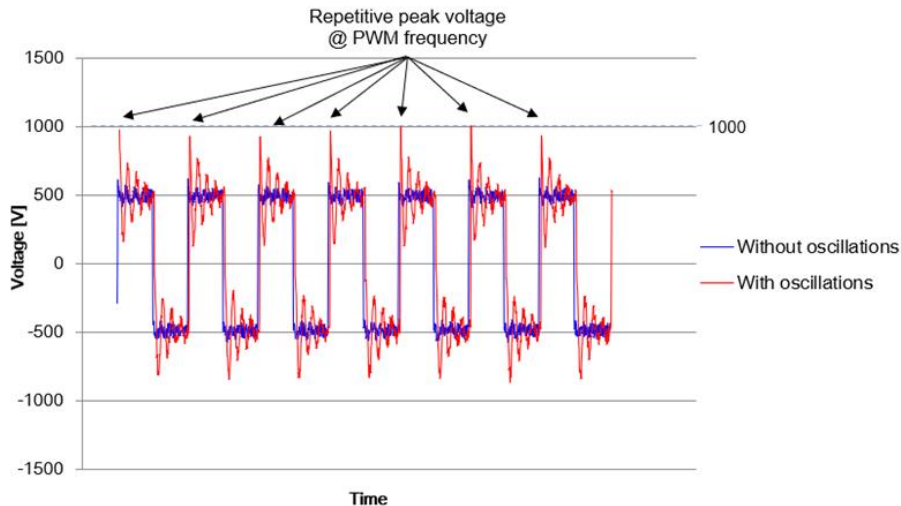

Table 5.4: 08S/10S/13S/18S/20S (B: High voltage) Series voltage limitation of power supply and neutral point

Item	18S/20S Series (B:High voltage)	08S/10S/13S Series (B:High voltage)
V_{bus}	Max. 750	Max. 600
$ V_{peak. to ground}^+ $	< 1000 V_p (phase to ground) @ PWM frequency	
$ V_{peak. to ground}^- $	< 1000 V_p (phase to ground) @ PWM frequency	
Voltage gradient $ dV/dt $	< 11kV/ μ s (instantaneous) If it is difficult to obtain instantaneous voltage gradient, the following formula can be used to estimate (Fig. 5.12): $ dV/dt = (90\%V_{pp} - 10\%V_p)/t_r $	

Fig. 5.14: Voltage oscillation schematic (600/750 V_DC controller)



5.2.2 Connecting iron-core/ironless motors

The temperature sensor system cable is routed as standard through the motor's extension cable. Both cables are therefore connected to the motor plug.

Note:

Check the technical information and approval drawing for pin assignment!

5.2.3 Connecting the linear positioning measurement system

⚠ Caution! Danger of EMC interference in the encoder signal!

- ▶ Approved ESD precautions must be followed at all times during read head and interface electrical connections.
- ▶ Make sure that the encoder cable has been shielded correctly!
- ▶ Ensure that the shielding is in full contact across the connectors!
- ▶ Ensure that the pairs of wires with the sin/cos signal are shielded separately!

⚠ Caution! Danger of injury!

- ▶ An incorrectly connected distance measuring system may cause uncontrolled carriage movements which can lead to injuries or might damage the linear axis.
- ▶ Only qualified personnel may connect the distance measuring system!

Note:

- The linear positioning measurement system is installed ready for operation in the linear motor system.
- Check the technical information and approval drawing for pin assignment!

Table 5.5: Connector

Type	Pole configuration	
D-Sub 9-pin (Male)		
Type	Pole configuration	
D-Sub 15-pin (Male)		

Table 5.6: Pin assignment

Pin no.	D-Sub 15-pin					D-Sub 9-pin
	Magnetic		Optical		Hall	Optical
	D	E	A	G, K	H	P
1	SIN-	-	V1-	-	SIN-	-
2	COS-	0V	V2-	0V	COS-	MA+
3	Ref+	-	V0+	-	Ref+	MA-
4	5V	Z-	5V	Z-	5V	5V
5	-	B-	5V	B-	-	5V
6	-	A-	-	A-	-	SLO+
7	-	5V	-	5V	-	SLO-
8	-	-	-	5V	-	0V
9	SIN+	-	V1+	0V	SIN+	0V
10	COS+	-	V2+	-	COS+	-
11	Ref-	-	V0-	-	Ref-	-
12	0V	Z+	0V	Z+	0V	-
13	-	B+	0V	B+	-	-
14	-	A+	-	A+	-	-
15	-	-	-	-	-	-
Plug housing	Shielding	Shielding	Shielding	Shielding	Shielding	Shielding

Table 5.7: Linear encoder parameter

D: Analog magnetic encoder	
Resolution	1 µm
Scale pitch	1 mm
Signal	analog, 1 Vpp sin/cos
E: Digital 1µm magnetic encoder	
Resolution	1 µm
Scale pitch	1 mm
Signal	digital, TTL 5V
A: analog optical encoder	
Resolution	0,1 µm
Scale pitch	40 µm
Signal	analog, 1 Vpp sin/cos
G: Digital 1µm optical encoder	
Resolution	1 µm
Scale pitch	40 µm
Signal	digital, TTL 5V
K: Digital 0,1µm optical encoder	
Resolution	0,1 µm
Scale pitch	40 µm
Signal	digital, TTL 5V
H: Analog hall encoder	
Resolution	1 µm (for D1)/ 7,5µm (for E1)
Scale pitch	30mm
Signal	analog, 1 Vpp sin/cos
P: Absolute optical encoder	
Resolution	0,5 µm absolute
Scale pitch	50 µm
Protocol	BiSS 26 bit

5.2.4 Connecting the limit switch

The optical or inductive proximity switches in design as limit switches are installed ready for operation in the linear motor system.

Note:

- Check the technical information and approval drawing for the position of limit switches.
- Check the technical information and approval drawing for pin assignment!

6 Commissioning

6.1 Switch on the linear motor system

⚠ Danger! Danger from strong magnetic fields!

Strong magnetic fields around linear motor systems pose a health risk to a person with implants (e.g. cardiac pacemakers) that are affected by magnetic fields.

- ▶ Anyone with implants that are affected by magnetic fields should maintain a safe distance of at least 500 mm from linear motor systems (trigger threshold for static magnetic fields of 0,5 mT as per directive 2013/35/EU).

⚠ Warning! Risk of crushing from strong forces of attraction!

Strong magnetic forces may attract steel or iron objects from the linear motor system and cause crushing!

- ▶ No heavy (> 1 kg) or large (> 0,01 m²) steel or iron objects should be held by hand into the immediate surrounding area (50 mm) of the magnet track!
- ▶ Use suitable tools only.

⚠ Warning! Risk of crushing from moving forcer housing!

The forcer housing may cause damage to parts through its movement at the end position of the machine.

- ▶ The operator should provide protective equipment to prevent from reaching into the danger area of the machine!

⚠ Warning! Risk of burns!

The motor heats up during operation so touching the motor can lead to burns!

- ▶ Provide protective devices and warning notices at the motor!

⚠ Caution! Risk of physical damage to watches and magnetic storage media.

Strong magnetic forces may destroy watches and magnetizable data storage media near to the linear motor system!

- ▶ Do not bring watches or magnetizable data storage media into close to (<300 mm) the linear motor systems!

⚠ Caution! Damage of the linear motor system!

Danger of material damage through uncontrolled movements of the forcer housing in the case of a power cut!

- ▶ Ensure that the dampers are fitted in the end positions on both sides of the linear motor system!
- ▶ No heavy load on the cover!
- ▶ No moving the forcer housing!

Note:

The operator should provide a controller according to EN ISO 12100 that prevents the machine from being started up unintentionally after power is restored, troubleshooting or the machine is stopped.

Steps to switch on the linear motor system:

- ▶ Switch off the controller.
- ▶ Pull out the motor cable.
- ▶ Connect positioning measurement system cable.
- ▶ Switch on the controller.
- ▶ Check the positioning measurement system (see separate assembly instructions for the drive and positioning measurement system).
- ▶ Switch off the controller.
- ▶ Connect the motor cable.
- ▶ Switch on the controller.
- ▶ Perform test run at slow speed.
- ▶ Perform test under usage conditions.

6.2 Programming

The programming of the linear motor system depends on the controller and drive used. Check the user manual for the controller and drive!

7 Maintenance and cleaning

7.1 Maintenance

⚠ Danger! Danger from electrical voltage!

Before and during maintenance and cleaning, dangerous currents may flow.

Work may only be carried out by a qualified electrician and with the power supply disconnected!

- ▶ Before carrying out work on the linear motor system, disconnect the power supply and protect it from being switched back on!

⚠ Danger! Danger from strong magnetic fields!

Strong magnetic fields around linear motor systems pose a health risk to a person with implants (e.g. cardiac pacemakers) that are affected by magnetic fields.

- ▶ Anyone with implants that are affected by magnetic fields should maintain a safe distance of at least 500 mm from linear motor systems (trigger threshold for static magnetic fields of 0,5 mT as per directive 2013/35/EU).

⚠ Warning! Risk of crushing from moving parts!

The forcer housing may cause damage to parts through its movement at the end position of the machine.

- ▶ The operator should provide protective equipment to prevent from reaching into the danger area of the machine!

⚠ Warning! Risk of burns!

The motor heats up during operation and thus touching the motor can lead to burns!

- ▶ After disconnecting the drive amplifier from the power supply, wait at least 5 minutes before removing the cover and touching the motor.

⚠ Warning! Unauthorized repairs on the system

Unauthorized work on the system creates the risk of injuries and may invalidate the warranty.

- ▶ The system must only be serviced by specialist personnel!

⚠ Caution! Risk of physical damage to watches and magnetic storage media.

Strong magnetic forces may destroy watches and magnetizable data storage media near to the linear motor systems!

- ▶ Do not bring watches or magnetizable data storage media into close to (<300 mm) of linear motor systems!

Note:

Use only suitable and non-hazardous agents. Please check the manufacturer's safety data sheets

Remove the cover or bellows before maintenance:

- ▶ As for the cover, loose the screws on the cover.
- ▶ Remove the cover carefully.

Fig. 7.1: Exploded view of the cover – here for an LMSSA 08/10/13 linear motor system

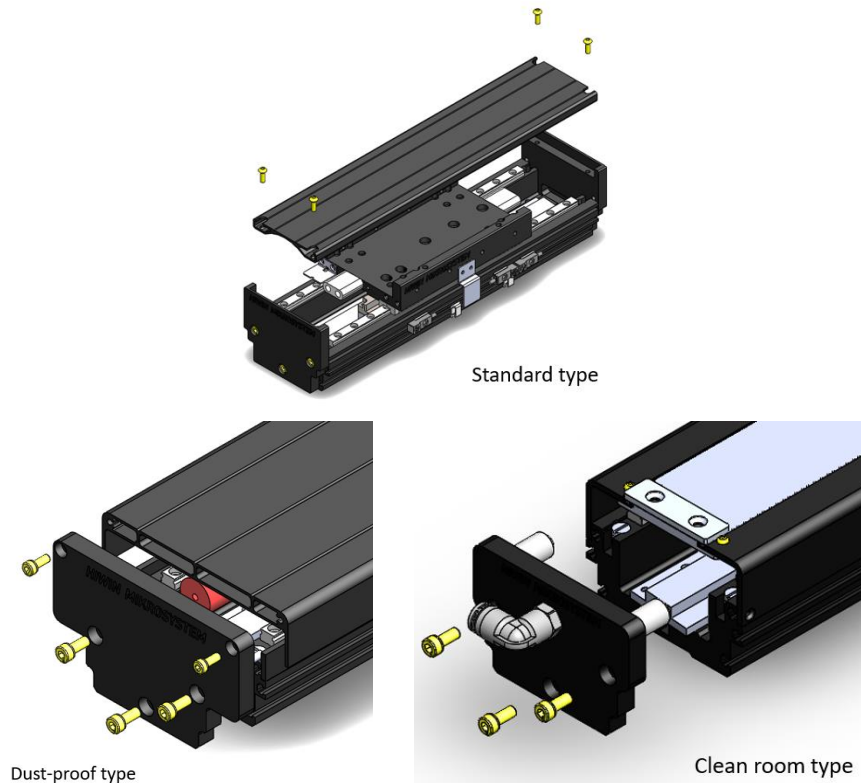

Fig. 7.2: Exploded view of the cover – here for an LMSSA 18/20 linear motor system

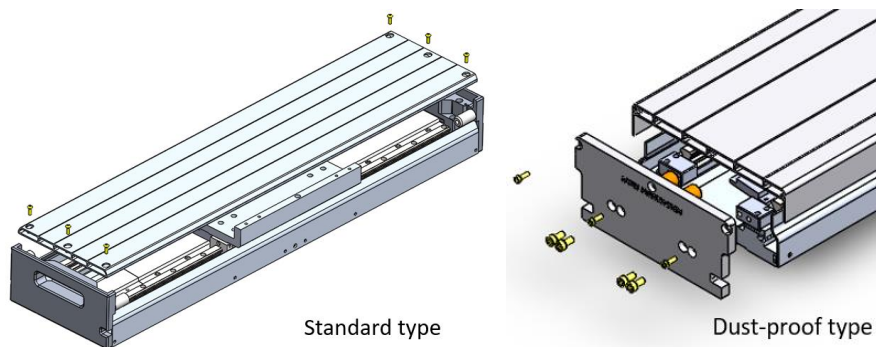

Table 7.1: Remove / mounting the cover

Suitable for linear axis	Cover type	Screw Size	Torque (Nm)
SSA-08, SSA-10	Standard	M4	3,3
		M5	5,8
	Dust-proof	M4	3,3
		M5	5,8
	Clean room	M5	5,8
SSA-13	S	M4	3,3
	M	M4	3,3
SSA-18	S	M4	3,3
SSA-20	S	M4	3,3

During maintenance:

- ▶ Secure the linear motor system against being switched on without authorization.
- ▶ Disconnect the power supply of the linear motor system.

Secure the linear motor system against being switched back on without authorization.

Fig. 7.3: Example of a warning sign

	Reference No. ISO 7010-M021
	Referent Disconnect before carrying out maintenance or repair
	Function To signify that the machine or the equipment, which is not connected to mains by a plug, has to be disconnected from all sources of power before carrying out maintenance or repair
	Image content Horizontal arrow pointing to the right; one vertical short thick line attached to a circle at the bottom with a longer thick line at an angle to the right attached to the top of the circle; a further thick line in the same plane as the lower one, separated from the line at an angle
Hazard Machine or equipment running during maintenance or repair Human behaviour that is intended to be caused after understanding the safety sign's meaning Disconnecting the machine or equipment before carrying out maintenance or repair Related referents ISO 7010-M006, ISO 7010-P031 Additional information Test data obtained according to ISO 9186-1:2007 are not available. Consequently, a supplementary text sign shall be used to increase comprehension except when the safety sign is supplemented by manuals, instructions or training.	

Installed the cover or bellows after maintenance:

- ▶ Position the cover on the linear motor system.
- ▶ Tighten the screws on the cover.

7.1.1 Linear motor

- Ensure that no parts are located between the forcer and the magnet track!
- The linear motor operates maintenance-free.

7.1.2 Positioning measurement system

Magnetic positioning measurement system

- Ensure that no dirt particles are located between the encoder and the measuring scale!

The magnetic positioning measurement system works on a non-contact basis and thus requires no maintenance. Check the magnetic positioning measurement system regularly for soiling, cleaning this when necessary. Otherwise, accumulating dirt particles will detach under the constant pressure of the cover plate.

Optical positioning measurement system

- Ensure that no extra particles caught between the encoder and the measuring scale! Only use soft cloth for cleaning to avoid scratching the measuring scale!

The optical positioning measurement system works on a non-contact basis and thus requires no maintenance. Regularly check the measuring scale for dirt and clean if necessary, as otherwise the surface of the measuring scale may become scratched and may no longer function correctly.

7.1.3 Electromechanical components

The energy chain and the cable have a limited lifetime. However, the lifetime cannot be calculated exactly due to ambient conditions and drive performance. The following components should therefore be regularly checked for wear and correct position, and should be replaced if necessary (wearing parts are not covered by the warranty):

- Cable in the energy chain (e.g. signs of abrasion on the cable insulation)
- Cable plug connections
- Distance between the limit switch shelter and sensors (common cause of malfunction of the limit/reference switch)

In critical production situations, make sure that there is a stock of wearing parts!

7.1.4 Linear guideways

Lubrication

As with rolling bearings, the rails of linear motor systems require a sufficient supply of lubricant. This lubrication reduces wear, protects against dirt and deposits, prevents corrosion and extends service life. Please read the instructions of the lubricant manufacturer.

Check the miscibility of different lubricants. Lubricants of the same classification (e.g. CL) and similar viscosity (maximum difference of one class) are miscible. Greases are miscible when their base oil and thickening types are the same. The viscosity of the base oil must be similar and the NGLI class may be different by a maximum of one grade.

- Ensure that old grease, dirt and chippings are removed from the profile rails before lubrication.
- Only use lubricants that are in accordance with DIN 51825, KP2K of the consistency class NGLI2.
- Ensure that only lubricants without solid lubricant particles (e.g. graphite or MoS₂) are used!
- Further information about lubrication and selection of approved lubricants can be found in the user manual for linear guideways at www.hiwin.tw.
- The clean room type (SSA-08/10/13) and Dust-proof type (SSA-08/10/13/18/20) are remove the end cover for lubrication.(See Fig. 7.4)

Fig. 7.4: Remove the end cover for lubrication (left: clean room type; right: dust-proof type)

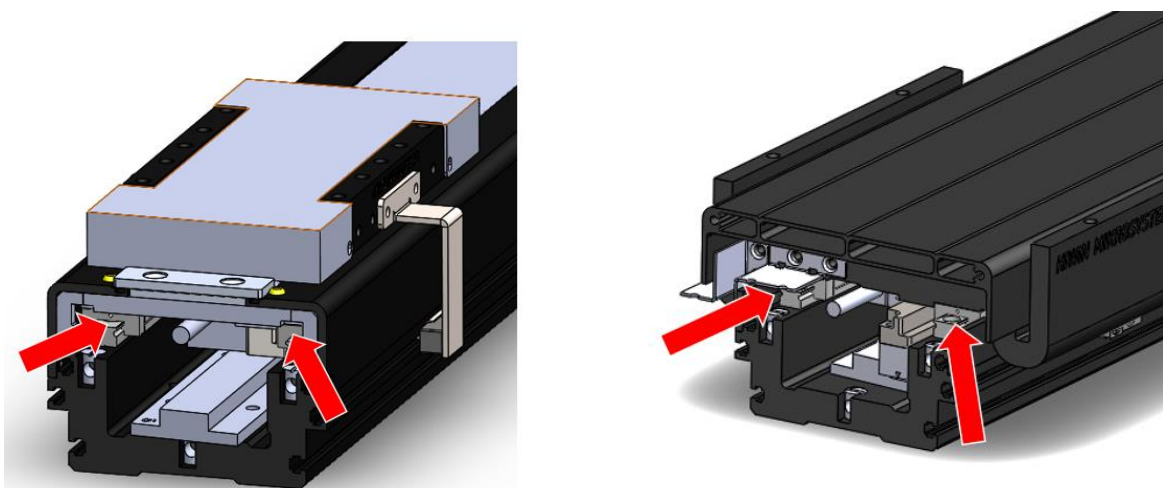
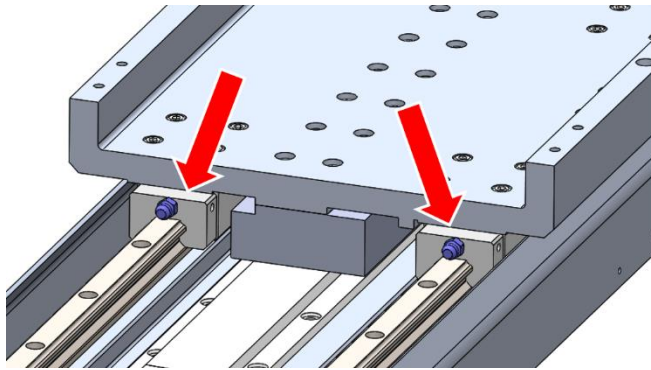

Fig. 7.5: Grease nipples on linear guideways (LMSSA 13, 18, 20)



Note:

- Relubricating interval. (See Fig. 7.4, Fig. 7.5)
- Relubricating grease quantity varies from different LMSSA size. (See Table 7.8)
- Relubrication with grease maintenance kit.

○ **SSA 08,10, MGN Block grease maintenance kit:**

A syringe is used to apply lubricant to the ports. The standard is a fully synthetic lubricant with a main constituent. Synthetic hydrocarbons (PAO). The viscosity class the oil is 680(ISO VG680).

Fig. 7.6: SSA 08, 10, MGN Block grease maintenance kit



Table 7.2: SSA 08, 10, grease syringe

Part No.	Part name	Specification	Schematic diagram
940303200002	Syringe	10 cc	
940301800006	Syringe Needle	20 1/2"45°	

Table 7.3: MOBIL VACTRA NO.2

Grade	ISO 68
Copper Strip Corrosion, 3 h, 100 C, Rating, ASTM D130	1B
FZG Scuffing, Fail Load Stage, A/8.3/90, ISO 14635-1	13
Flash Point, Cleveland Open Cup, °C, ASTM D92	228
Kinematic Viscosity @ 40 C, mm2/s, ASTM D445	68
Pour Point, °C, ASTM D97	-18

Table 7.4: MOLYTOG PFM-5590

Color	White
Base Oil	Synthetic oil
Kinematic Viscosity @ 40°C, mm2/s	310
Viscosity [cst]	>300
Service Temperature (°C)	-60~250
Evaporation losses @ 204°C, 22hr (%)	0,5

○ SSA 13,18,20 grease maintenance kit:

Fig. 7.7: SSA 13, 18, 20 grease maintenance kit

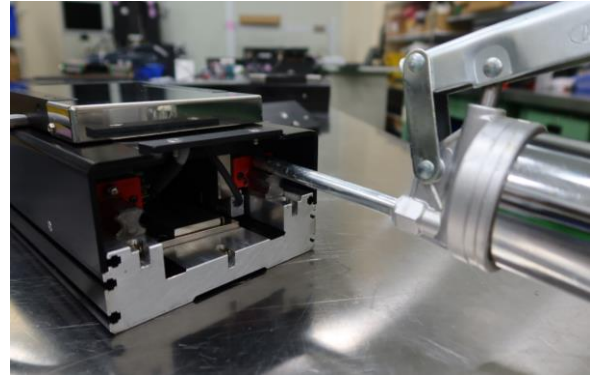

Table 7.5: SSA 13, 18, 20, grease gun

Model no.	GN-80M	GN-400C
Dimension		
Specification	<ul style="list-style-type: none"> ○ Working pressure: 15 Mpa ○ Output: 0,5–0,6 c.c./Stroke ○ Weight: 520(g) grease excluded ○ Grease reload: 70 g flexible tube or 120 ml bulk loading 	<ul style="list-style-type: none"> ○ Working pressure: 15 Mpa ○ Output: 0,8–0,9 c.c./Stroke ○ Weight: 1150(g) grease excluded ○ Grease reload: 14 o.z. cartridge pipe or 440 ml bulk loading

Table 7.6: G04 Basic properties

Color	Beige
Base Oil	Ester/PAO
Consistency Enhancer	Lithium soap
Service Temperature (°C)	-35–120
NLGI-grade [0,1mm]	260–280
Viscosity [cst]	40°C: 25 100°C: 6
Drop Point (°C)	>225

Table 7.7: G03 Basic properties

Color		Beige
Base Oil		Synthetic
Hydrocarbon oil		
Consistency Enhancer		Special calcium soap
Service Temperature (°C)		-45–125
NLGI-grade [0,1 mm]		265–295
Viscosity [cst]	40°C	30
	100°C	5,9
Drop Point (°C)		>210

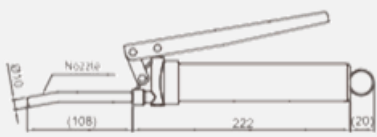
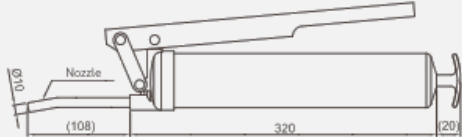
Table 7.8: Lubricant quantities for the linear guideway of the linear axes SSA

Size	Type	Block	Lubricant	Relubrication quantity [cm ³]
LMSSA-08S	Standard, Dust-proof	MGN9	MOBIL VACTRA NO.2	0,06
	Clean room		MOLYTOG PFM-5590	
LMSSA-10S	Standard, Dust-proof	MGN9	MOBIL VACTRA NO.2	0,06
	Clean room		MOLYTOG PFM-5590	
LMSSA-13S	Standard, Dust-proof	QH15	G04	0,3
	Clean room		G03	
LMSSA-18S	Standard, Dust-proof	QH15	G04	0,3
LMSSA-18C	Standard, Dust-proof	QH15	G04	0,3
LMSSA-20S	Standard, Dust-proof	QH20 (Other)	G04	0,5
		QH20 (20S500)		0,7
LMSSA-20C	Standard, Dust-proof	QH15	G04	0,3

○ Relubrication intervals for grease lubrication

Among other conditions, the relubrication intervals depend on the P/C load ratio, where P stands for the dynamically equivalent load and C stands for the dynamic load rating.

The relubrication intervals can possibly be shortened under the following conditions. In such cases, please consult HIWIN: $v > 3 \text{ m/s}$, $a > 30 \text{ m/s}^2$ and contact with media, temperatures $< 20^\circ\text{C}$ or $> 30^\circ\text{C}$, soiled ambient conditions.

Fig. 7.8: Relubrication intervals with grease lubrication, one-sided and two-sided long-term lubrication unit for MG.

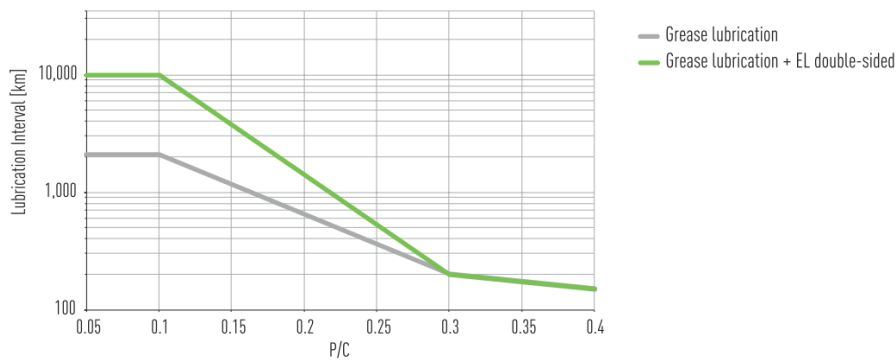
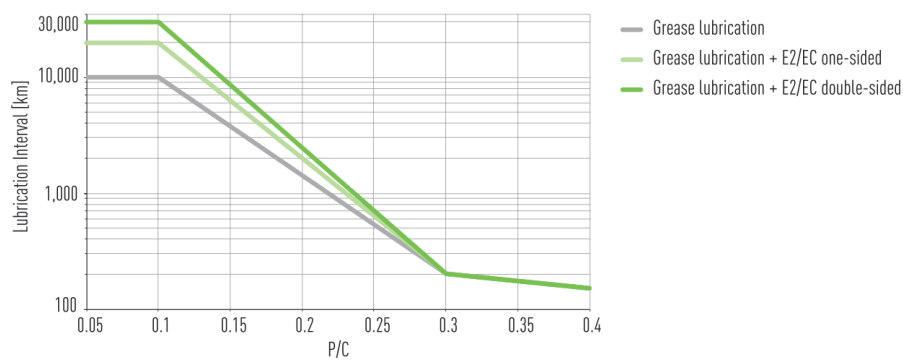

Fig. 7.9: Relubrication intervals with grease lubrication, one-sided and two-sided long-term lubrication unit for QH.



7.1.5 Cleaning

Dirt can settle and accumulate over time on unprotected profile rails. Profile rails must therefore be regularly checked for dirt and cleaned if necessary. Stage can start motion after cleaning the excessive grease:

- ▶ Clean the overflows on guideway and blocks
- ▶ Clean the optical encoder and scale
- ▶ Clean the stator.

Note:

- Please apply IPA on wiper for cleaning. Do not apply the IPA on the scale directly.
- Do not use Ethanol or any other solvent to clean up optical scale.
- There is strong magnetic force between LMSA motor's forcer and stators. When cleaning the motor, the forcer and stator can't be too close to each other.
- LMC stator is not suitable on the following maintenance procedure. If the stator has been attracted with each other, please contact HIWIN staff to assist it
- If the stage is used under unideal environment, cleaning on stators should be performed regularly.
- Stators and forcers (iron materials) can make powerful suction, which would hurt fingers and palms seriously. Don't let magnetic items get too close to avoid magnet attract. (E.g. Knife, tools.)

7.1.6 Test run

After lubricating, please cycle run the stage for over 10 minutes before regular usage, which could evenly distribute the grease between the block and guideway. This could also release the saturation pressure and avoid the grease continuing to overflow and accumulating between the block and the guideway.

8 Disposal

8.1 Waste disposal

⚠ Caution! Danger caused by environmentally hazardous substances!

The danger to the environment depends on the type of substance used.

Clean contaminated parts thoroughly before disposal!

- ▶ Clarify the requirements for safe disposal with disposal companies and, where appropriate, with the competent authorities!

Table 8.1: Disposal

Fluids	
Lubricants	dispose of as hazardous waste in an environmentally friendly way
Soiled cleaning cloths	dispose of as hazardous waste in an environmentally friendly way
Linear motor system	
Cabling, electrical components	dispose of as electrical waste
PP components (e.g. cable chain)	dispose of separately
Steel components (e.g. guideways)	dispose of separately
Aluminium components (e.g. base)	dispose of separately

9 Troubleshooting

9.1 Troubleshooting

Table 9.1: Fault table

Symptom	Cause	Action
Motor does not start	Power supply cables disconnected	Check connections. Plug contacts may be compressed, repair if necessary.
	Fuse has tripped via motor protection	Check motor protection for the right settings. Fix defects if necessary
Upon restart, the drive reports a fault during commutation	Encoder counting direction incorrect	Change the sin and cos pair of wires in the encoder plug
	Forcer housing is too close to the limit switch/limit stop	Disconnect power supply to axis and move forcer housing manually into the centre of the axis.
	Additional drive resistance	Change parameters in the drive amplifier
Axis overspeeds upon restart	Commutation incorrect	See fault during commutation Check commutation parameters in the drive, activate speed monitoring!
	EMC interference with the encoder signal	Check the shielding of the connectors and cables
Axis overspeeds in positioning mode	Programming error in the position transfer, invalid acceleration ordered	Activate security settings in the drive amplifier, such as speed monitoring, permissible position errors etc.
Motor heats up too much (measure temperature)	Rated power exceeded as duty cycle is too long	Adapt load cycle to the rated power of the motor
	Cooling insufficient	Fix cooling air power supply or open cooling air passages. Retrofit external fan if necessary
	Forcer housing is difficult to move	Check lubrication of the guideways, foreign bodies in the moving range.
	Ambient temperature is too high	Check permissible temperature range
	Load cycle has been modified	Calculate load cycle and adapt accordingly
	Drive amplifier motor commutation does not function properly	Adapt commutation parameters of the drive amplifier
Operating noise from the forcer	Relubrication required otherwise risk of bearing damage	Lubrication or consultation with HIWIN
The axis generates cracking noises when it is subject to control	EMC interference in the encoder signal	Encoder cables must be used separately with shielded sin and cos signal pairs
	Commutation incorrect	Optimize commutation parameters.
The forcer jerks while moving and generates operating noise that is not caused by the profile guideways	EMC interference in the encoder signal. Encoder cable plug connection defective. Pin bent in plug	Place motor cable and/or encoder cable shield in full contact with the grounding terminal of the amplifier, check pin in plug.
Position discrepancies after several hours of operation		Use mains filter to stabilize voltage

10 Declaration of Incorporation

In accordance with EU Machinery Directive 2023/1230 Annex V Part B on the installation of incomplete machinery

The manufacturer:

HIWIN GmbH
Brücklesbünd 1
77654 Offenburg

Documentation department:

HIWIN GmbH, Brücklesbünd 1, 77654 Offenburg

Description and identification of the incomplete machine:

Product designation: Linear motor axis
Series/type designation: LMSSA
Year of manufacture: from 2025

It is declared that the following essential requirements of EU Machinery Regulation 2023/1230 Annex III Part B are met:

1.1.2, 1.1.3, 1.1.4, 1.1.5, 1.1.6, 1.1.7, 1.3.1, 1.3.2, 1.3.3, 1.3.4, 1.5.1, 1.5.2, 1.5.3, 1.5.4, 1.5.8, 1.5.11, 1.6.1, 1.6.5, 1.7.1, 1.7.2, 1.7.3, 1.7.4, 1.7.5

It is also declared that the specific technical documentation has been compiled in accordance with Annex IV, Part B.

It is expressly declared that the incomplete machine complies with all relevant provisions of the following EC directives.

2023/1230/EU Machinery Regulation
2014/30/EU Electromagnetic Compatibility (EMC) Directive
2014/35/EU Low Voltage Directive
2011/65/EU RoHS Directive on the restriction of hazardous substances

Reference to the harmonised standards applied in accordance with Article 20(1)

EN ISO 12100:2010	Safety of machinery – General principles for design – Risk assessment and risk reduction (ISO 12100)
EN 60204-1:2018	Safety of machinery – Electrical equipment of machines – Part 1: General requirements
IEC 61000-6-2:2019	Electromagnetic compatibility (EMC) – Part 6-2: Generic standards – Immunity for industrial environments
IEC 61000-6-4:2019	Electromagnetic compatibility (EMC) – Part 6-4: Generic standards – Disturbance immunity for industrial environments

The manufacturer or authorised representative undertakes to provide national authorities with the specific documentation relating to the incomplete machinery upon reasoned request.

Industrial property rights remain unaffected by this!

Important note! The incomplete machine may only be put into service after it has been established that the machine into which the incomplete machine is to be incorporated complies with the provisions of this directive.

Offenburg, June 2025

Werner Mäurer, Management

11 Appendix

11.1 Glossary

○ Accuracy

This, or actually the better terminology, the inaccuracy, corresponds to the deviation between target and actual position. The accuracy along an axis is defined as the remaining difference of target and actual position, after other linear deviations are excluded. Such systematic or linear deviations can be caused by cosine error, angle deviation, ball screw error, thermal expansion, etc. For all target positions of interest in an application, it is calculated with the following formula:

Maximum of sum of systematic target–actual-difference+ 2 sigma (standard deviation)

Please do not confuse accuracy with repeatability.

○ Acceleration

This is the speed change per time unit, i.e., acceleration = speed/time or $a = v/t$.

○ Acceleration time

This is defined as the time a drive requires from start until achieving target speed.

○ Attraction force (F_a)

This is created between the primary and secondary parts of the iron core linear motors which must be provided by the guide.

○ Back EMF constant(K_v)

This is the ratio of the back EMF voltage (rms) to the motor rotational speed or linear speed (rpm or m/s). The back EMF is the electromagnetic force, which is created at the movement of the coil in the magnetic field of permanent magnets, e.g. in a servo motor.

○ Continuous force (F_c)

Continuous force are also called nominal torque and nominal force. This is the force that linear motors can produce in continuous operation when continuous current of 100% load rate (duty cycle) is applied to the motor coil.

○ Continuous current (I_c)

Continuous current is defined as the maximum allowed current into each coil under continuous operation, and is also called nominal current. It is characterized when the motor warms up and stay at 80 °C.

○ Eccentricity

This is the deviation of the centre point of rotation of rotary tables from their position during rotation. It is created by centring and bearing tolerances.

○ Force

Force (in linear movements) is given for defined conditions, e.g., as continuous force or torque at:

- 20 °C ambient temperature
- 80 °C winding temperature
- 100 % rate of loading (duty cycle)

or as peak force or peak torque.

○ Force constant (K_f)

This is a coil specific constant. The motor output force can be calculated by multiplying the force constant of the motor by input current: $F=I \times K_f$

○ Guide deviation

This is the deviation from the axis of stroke. It depends on horizontal straightness [also straightness] and vertical straightness [also flatness].

- **Horizontal straightness**

Horizontal straightness is defined as the positioning error in Y-axis as the stage moves along X-axis, which is measured by laser interferometer system.

- **Motor constant (K_m)**

Motor constant designates the ratio of generated force and dissipation power, and represents the efficiency of the motor.

- **Peak current (I_p)**

Peak current is applied to coils for a short time to generate peak force. The maximum time for applying peak current is 1 second. After that, motor has to cool down to nominal operating temperature, before further peak current could be applied again.

- **Peak torque, peak force (F_p)**

The peak torque [for rotary motion] or peak force [for linear motion] is the maximum force that a motor can generate for approximately one second with peak current I_p . While applying I_p into motor, it is operating near the non-linear range of motor. This is especially useful for acceleration and braking.

- **Resolution**

Resolution is the smallest distance that the position measuring system can detect. The reachable step size is theoretically larger than resolution due to other additional factors.

- **Repeatability**

Repeatability is the measure of how close a stage approach to a designated point in different runs. Repeatability should not be confused with absolute accuracy. A linear axis can have medium accuracy, but have good repeatability. Uni-directional repeatability can be measured in a way, that a target position is approached multiple times from an appropriately distance and the same approaching direction. In this way, the backlash will not have any effect. For measurement of bi-directional repeatability, the target position is approached from different directions, in which case the backlash will take effect.

- **Stiffness**

Static stiffness stands for the mechanical resistance to deformation of a part or an assembly under external static payload. In the other hand, dynamic stiffness stands for the elastic resistance to deformation and movement of a part or an assembly under external dynamic payload (e.g. driving force).

- **Step size**

The minimum step size is close to resolution. It is the smallest possible movement of a system. It depends on encoder, amplifier, mechanical structure, backlash, etc.

- **Vertical straightness**

Vertical straightness is defined as the positioning error in Z-axis as the stage moves along X-axis, which is measured by laser interferometer system.

- **Winding resistance R_{25}**

R_{25} is the winding resistance at 25 °C. At 80 °C, the winding resistance increases to approximately $1,2 \times R_{25}$.

- **Winding temperature (T)**

This is the permitted winding temperature. The actual motor temperature is dependent on the installation, cooling and operating conditions and consequently can only be determined in a concrete case and cannot be calculated.

11.2 Unit conversion

To convert the unit in column B to the unit in column A, multiply by the corresponding figure in the table.

○ Mass

Table 11.1:

		B			
		g	kg	lb	oz
A	g	1	0,001	0,0022	0,03527
	kg	1000	1	2,205	35,273
	lb	453,59	0,45359	1	16
	oz	28,35	0,02835	0,0625	1

○ Linear velocity

Table 11.2:

		B				
		m/s	cm/s	mm/s	ft/s	in/s
A	m/s	1	100	1000	3,281	39,37
	cm/s	0,01	1	10	$3,281 \times 10^{-2}$	0,3937
	mm/s	0,001	0,1	1	$3,281 \times 10^{-3}$	$3,937 \times 10^{-2}$
	ft/s	0,3048	30,48	304,8	1	12
	in/s	0,0254	2,54	25,4	$8,333 \times 10^{-2}$	1

○ Force

Table 11.3:

		B		
		N	lb	oz
A	N	1	0,2248	3,5969
	lb	4,4482	1	16
	oz	0,2780	0,0625	1

○ Length

Table 11.4:

		B				
		m	cm	mm	ft	in
A	m	1	100	1000	3,281	39,37
	cm	0,01	1	10	$3,281 \times 10^{-2}$	0,3937
	mm	0,001	0,1	1	$3,281 \times 10^{-3}$	$3,937 \times 10^{-2}$
	ft	0,3048	30,48	304,8	1	12
	in	0,0254	2,54	25,4	$8,333 \times 10^{-2}$	1

- Temperature

Table 11.5:

		B	
		°C	°F
A	°C	1	$(°F - 32) \times 5 / 9$
	°F	$(°C \times 9 / 5) + 32$	1

11.3 Tolerances and hypotheses

11.3.1 Tolerances

Table 11.6: Tolerances

Tolerances (mm)							
<6	6–30	30–120	120–300	300–600	600–1200	1200–2400	>2400
±0,1	±0,2	±0,3	±0,4	±0,5	±0,8	±1,0	±1,5

11.3.2 Hypotheses

Operating staff are trained in the safe operation practices for linear motor systems and have read and understood this user manual in full. Maintenance staff maintain and repair the linear motor systems in such a way that they pose no danger to people, property or the environment.

11.4 Supplementary formula

11.4.1 Start Motor Sizing

The following contents describe how to choose proper motor according to speed, moving distance, and payload inertia. The basic process for sizing a motor is:

- Decide motion profile and required parameters
- Calculate peak and continuous force
- Select motor

Symbols

X	Move distance (mm)
T	Move time (sec)
a	Acceleration (mm/s ²)
V	Velocity (mm/s)
M _L	Payload (kg)
g	Gravitation acceleration (mm/s ²)
F _P	Peak force (N)
F _C	Continuous force (N)
F _a	Attraction force between stator and forcer (N) applicable for LMSSA series
F _I	Inertia force (N)
K _P	Force constant (N/Arms)
I _P	Peak current (Arms)
I _e	Effective current (Arms)
I _C	Continuous current (Arms)
V ₀	Starting velocity (mm/s)

○ **STEP 1 Decide motion velocity profile and required parameters**

In order to determine the correct motor for a particular application it is necessary to be familiar with the motion equation.

– Motion equation

Basic kinematics equations are described as follows:

$$V = V_0 + aT$$

$$X = V_0T + \frac{1}{2}aT^2$$

Where V is velocity, a is acceleration, T is move time and X is move distance.

You can choose two of the four parameters (V, a, T and X) as your designed parameters, then the last two parameters can be calculated by above equations.

– Motion velocity profile

○ 1/3-1/3-1/3 trapezoid profile

If the distance (X) and move time [T] have been given, the most common and efficient velocity profile for point-to-point motion is the “1/3-1/3-1/3” trapezoid curve because it provides the optimal move by minimizing the power required to complete the move. It breaks the time of the acceleration, Stroking, and deceleration into three segments as shown below.

Fig. 11.1: Trapezoid profile

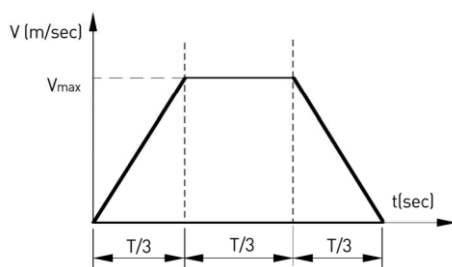

$$V_{\max} = 1,5 \times \frac{X}{T} \quad (\text{Because } X = \frac{V}{2} \times \frac{T}{3} + V \times \frac{T}{3} + \frac{V}{2} \times \frac{T}{3})$$

$$a_{\max} = \frac{V_{\max}}{T/3} = \frac{4,5X}{T^2}$$

Note:

Here in the parameters are described as motion equation.

○ 1/2-1/2 triangle profile

If X and T are given, another common motion profile is the 1/2-1/2 triangle profile. The motion is divided into two parts, namely acceleration and deceleration. The second motion velocity profile is shown as follows.

Fig. 11.2:

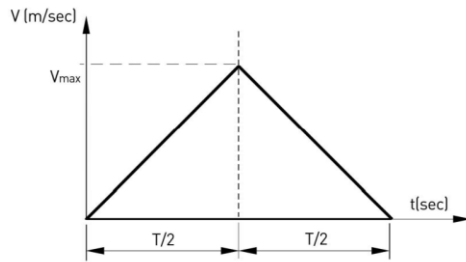

$$V_{\max} = 2 \times \frac{X}{T}$$

$$a_{\max} = \frac{4X}{T^2}$$

○ Some useful equations

Table 11.7:

	1/3 -1/3-1/3 Trapezoid profile	Triangle profile
V	$1,5 \times \frac{X}{T}$	$2 \times \frac{X}{T}$, or $\sqrt{a \times X}$
a	$\frac{4,5X}{T^2}$	$\frac{4X}{T^2}$
t	$\frac{X}{V_{\max}} + \frac{V_{\max}}{a}$ (if $\frac{X}{V_{\max}} \geq \frac{V_{\max}}{a}$)	-

The acceleration required in the first motion velocity profile is bigger than that in the second motion velocity profile; therefore, the required motor size is bigger. When choosing second motion velocity profile, the chosen motor size is smaller, however, we need to verify the DC bus of driver is bigger enough, due to the higher velocity (V_{\max}).

STEP 2 Determine peak force and effective force

The peak force can be calculated by the follow equation

$$F_p = M_L \times a_{max} + (M_L \times g + F_a) \times \mu = F_i + F_f$$

Where F_i is inertia force while F_f is friction force, and μ is friction factor.

In most cases, motions are cyclic point-to-point movements. Assuming a cyclic motion shown in the following profile with a pause time of t_4 second, the effective force can be calculated as following formula:

$$F_e = \sqrt{\frac{(F_i + F_f)^2 t_1 + F_f^2 t_2 + (F_i - F_f)^2 t_3}{t_1 + t_2 + t_3 + t_4}}$$

Fig. 11.3: Profile

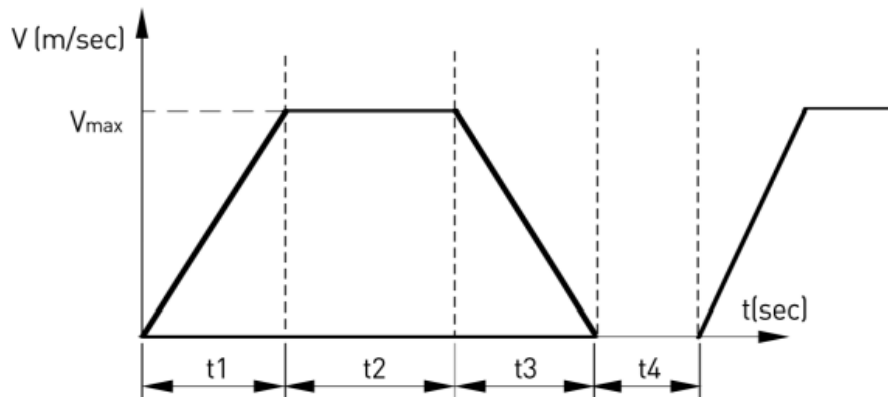

The peak current I_p and effective current I_e can be calculated by using motor force constant K_f .

$$I_p = \frac{F_p}{K_f}$$

$$I_e = \frac{F_e}{K_f}$$

STEP 3 Select motor by peak force and verify the current supply of motor

From the HIWIN catalogue, you can check the specifications of motor and choose an applicable motor by peak force, and then you can verify the current supply if it is fitted the specification as follows.

$$I_p = \frac{F_p}{K_f} < I_p \text{ (from specification of chosen motor)}$$

$$I_e = \frac{F_e}{K_f} < I_c \text{ (from specification of chosen motor)}$$

Regarding effective and continuous current, the ratio of I_e/I_c had better be less than 0,7 to attain some margin.

11.4.2 Linear Motor Sizing Example

For example, if Payload is 5 kg (moving mass of mechanism is 1 kg and payload is 4 kg), friction factor U is 0,01, distance is 500 mm, move time is 400 ms and dwell time is 350 ms.

At first, we can calculate the V_{max} , a_{max} , F_p and F_e by the formulas described above (choose the first motion velocity profile and LMSA Series)

$$V_{max} = 1,5 \times \frac{X}{T} = 1,5 \times \frac{0,5}{0,4} = 1,875 \text{ (m/sec)}$$

$$a_{max} = \frac{4,5 \times X}{T^2} = \frac{4,5 \times 0,5}{(0,4)^2} = 14,06 \text{ (m/sec}^2\text{)}$$

$$F_p = M_L \times a_{max} + (M_L \times g + F_a) \times \mu$$

$$= 5 \times 14,06 + 5 \times 9,81 \times 0,01 = 70,3 + 0,49 = 70,79 \text{ (N)}$$

$$F_e = \sqrt{\frac{[(70,3 + 0,49)^2 + 0,49^2 + (70,3 - 0,49)^2] \times 0,1333}{0,4 + 0,35}}$$

$$= 41,92(\text{N})$$

In this case, we can choose motor of type LMSA11 which can provide up to 289(N) of peak force and continuous force 103(N), and the force constant is 48,6 N/A (rms). Then the current supply of motor can be determined as follows

$$I_p = \frac{F_p}{K_f} = \frac{70,79}{48,6} = 1,46(\text{Arms}) < 6,3(\text{Arms})$$

$$I_e = \frac{F_e}{K_f} = \frac{41,92}{48,6} = 0,86(\text{Arms}) < 2,1(\text{Arms})$$

$$\frac{I_e}{I_c} = \frac{0,86}{2,1} \times 100\% = 40,9 < 70\%$$

11.4.3 Sizing a Regen Resistor

Gather required information

To calculate the power and resistance of the regen resistor requires information about the amplifier and the motor. For all applications, gather the following information:

- Detail of motion profile, including acceleration and velocity
- Amplifier model number
- Applied line voltage to amplifier
- Toque/force constant of the motor
- Resistance (line-to-line) of the motor windings

For rotary motor applications, gather additional information.

- Payload inertia seen by the motor
- Inertia of the motor

For linear motor applications, gather additional information

- Moving mass

Observe the properties of each deceleration during a complete cycle of operation

For each deceleration during the motion cycle, determine:

- Speed at the start of the deceleration
- Speed at the end of the deceleration
- Time over which the deceleration takes place

Calculate energy returned for each deceleration

The energy returned during each deceleration can be calculated by the following formulas.

Linear motor:

$$E_{\text{dec}} = \frac{1}{2} M_t (V_1^2 - V_2^2)$$

E_{dec} (joules): Energy returned by the deceleration

M_t (kg): Moving mass

V_1 (meters /sec): Velocity at the start of deceleration

V_2 (meters /sec): Velocity at the end of deceleration

Determine the amount of energy dissipated by the motor

Calculate the amount of energy dissipated by the motor due to current flow through the motor winding resistance using the following formula.

$$P_{\text{motor}} = \frac{3}{4} R_{\text{winding}} \left(\frac{F}{K_t} \right)^2$$

P_{motor} (watts): Power dissipated in the motor

R_{winding} (ohm): Line to Line resistance of the motor coil

F (N): Force need to decelerate the motor

K_t (N/Amp): Torque constant for the motor

$$E_{\text{motor}} = P_{\text{motor}} T_{\text{decel}}$$

E_{motor} (joules): Energy dissipated in the motor

T_{decel} (seconds): Time of deceleration

Determine the amount of energy returned to the amplifier

Calculate the amount of energy that will be returned to the amplifier for each deceleration using the following formula.

$$E_{\text{returned}} = E_{\text{dec}} - E_{\text{motor}}$$

E_{returned} (joules): Energy returned to the amplifier

E_{dec} (joules): Energy returned by the deceleration

E_{motor} (joules): Energy dissipated in the motor

Determine if energy returned exceeds amplifier capacity

Compare the amount of energy returned to the amplifier in each deceleration with the amplifier's absorption capacity. The following formula is used to determine the energy that can be absorbed by the amplifier.

$$W_{\text{capacity}} = \frac{1}{2} C (V_{\text{regen}}^2 - (1,414 V_{\text{mains}})^2)$$

W_{capacity} (joules): The energy that can be absorbed by the bus capacitor

C (farads): Bus capacitance

V_{regen} (volts): Voltage at which the regen circuit turns on

V_{mains} (volts): Mains voltage (AC) applied to the amplifier

Calculated energy to be dissipated for each deceleration

For each deceleration where the energy exceeds the amplifier's capacity, using the following formula to calculate the energy that must be dissipated by the regen resistor.

$$E_{\text{regen}} = E_{\text{returned}} - E_{\text{amp}}$$

E_{regen} (joules): Energy that must be dissipated in the regen resistor

E_{returned} (joules): Energy delivered back to the amplifier from the motor

E_{amp} (joules): Energy that the amplifier will absorb

Calculate pulse power of each deceleration that exceeds amplifier capacity

For each deceleration where energy must be dissipated by the regen resistor, use the following formula to calculate the pulse power that will be dissipated by the regen resistor.

$$P_{\text{pulse}} = E_{\text{regen}} - T_{\text{decel}}$$

P_{pulse} (watts): Pulse power

E_{regen} (joules): Energy that must be dissipated in the regen resistor

T_{decel} (seconds): Time of deceleration

Calculate resistance needed to dissipate the pulse power

Using the maximum pulse power from the previous calculation, calculate the resistance value of the regen resistor required to dissipate the maximum pulse power.

$$R = V_{\text{regen}}^2 / P_{\text{pulse max}}$$

R (ohms): Resistance

P_(pulse max): The maximum pulse power

V_{regen}: The voltage at which the regen circuit turns on

Choose a standard value of resistance less than the calculated value. The value must also be greater than the minimum regen resistor value specified by the amplifier supplier.

11.5 Optional accessories

- Fixing clamp

Fixing clamp is a convenient gadget for installing the linear axis to the machine frame from above. The fixing clamp can be put into grooves on the side of the stage.

Fig. 11.4: Fixing clamp

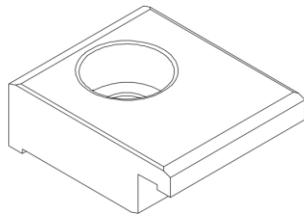

Fig. 11.5: Hole spacing for the lateral securing of SSA with fixing clamp

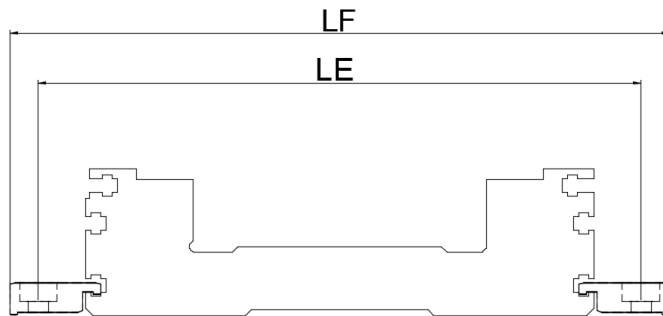

Fig. 11.6: Securing with fixing clamp - SSA-08/10/13 series

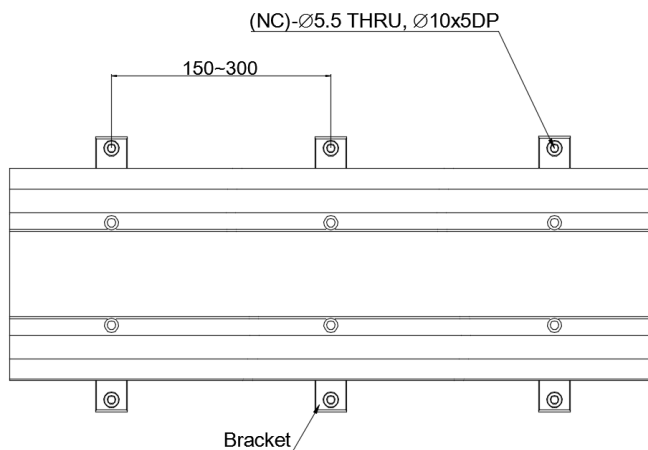

Table 11.8: Minimum number of fixing clamp for securing the stage

Part number	Specification	NC	LE	LF
200300100262	SSA-08	≥6	105	120
	SSA-10		125	140
	SSA013		160	175

○ Encoder extension cable

Table 11.9: Minimum number of fixing clamp for securing the stage







Drive	Encoder signal	Hall sensor	Part number (2 m)	Part number (4 m)
D2T	Digital	N	HE00EJ6DF200	HE00EJ6DF400
D1	Analog	Y	HE00VJQ85800	HE00VJQ85900
D1	Analog	N	HE00VJQ85600	HE00VJQ85700
D1	Digital	Y	HE00VJQ87200	HE00VJQ87400
D1	Digital	N	HE00VJQ84200	HE00VJQ84400
E1	Analog	Y	HE00EJVDA200	HE00EJVDA400
Drive	Encoder signal	Hall sensor	Article number (2 m)	Article number (4 m)
E1	Analog	N	HE00EK1DA200	HE00EK1DA400
E1	Digital	Y	HE00EKTDA200	HE00EKTDA400
E1	Digital	N	HE00EJ6DF200	HE00EJ6DF400
E1	Absolute	N	HE00EKSDA200	HE00EKSDA400

11.6 Customer request form

Company Name*:	Industry*:	Filled/Confirmed	/
Equipment*:	Application*:	Date:	Budget:

*Please fill all the required field 1 – 6

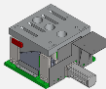
1 Stage Structure (multiple choices accepted) *

	Single Axis	Cross Table	Gantry	Bridge	Ball Screw	SBH Series	DLF Series	Custom
Type								(Please click the option on P3 or provide a sketch image)
Click	<input type="checkbox"/>	<input type="checkbox"/>	<input type="checkbox"/>	<input type="checkbox"/>	<input type="checkbox"/>	<input type="checkbox"/>	<input type="checkbox"/>	<input type="checkbox"/>

2 Stage Installation (multiple choices accepted) *

Options : A Horizontal, B Upside-down, C Wall-mounted, D Vertical, E Others

Ex:	Upper Axis	Lower Axis	Vertical Axis	Rotary Axis	Other	Other
<input type="checkbox"/> ___ <input type="radio"/> A ___	<input type="checkbox"/> _____	<input type="checkbox"/> _____	<input type="checkbox"/> _____	<input type="checkbox"/> _____	<input type="checkbox"/> _____	<input type="checkbox"/> _____

3 Operation Environment A – D (multiple choices accepted) *

Options	<input type="checkbox"/> <input type="radio"/> A General	<input type="checkbox"/> <input type="radio"/> B Temp. Range	<input type="checkbox"/> <input type="radio"/> C Clean room w/ constant temp. *(please fill routing information on P2)	<input type="checkbox"/> <input type="radio"/> D Vacuum
Spec	___°C ±1°C	___°C ± ___°C	Class ___ @ ___°C ±1°C	___ Torr or ___ mbar

4 Input Voltage *

<input type="checkbox"/> 110 V	<input type="checkbox"/> 220 V	<input type="checkbox"/> 380 V	<input type="checkbox"/> Other: _____ V
--------------------------------	--------------------------------	--------------------------------	---

5 Motor Sizing (multiple choices accepted) (Please fill "NA" if not assigned) *

	<input type="checkbox"/> Upper Axis	<input type="checkbox"/> Lower Axis	<input type="checkbox"/> Vertical Axis	<input type="checkbox"/> Rotary Axis	<input type="checkbox"/> Other	<input type="checkbox"/> Other
Axis Name						
Forcer Qtys						
Motion Type	<input type="checkbox"/> LM <input type="checkbox"/> BS	<input type="checkbox"/> LM <input type="checkbox"/> BS	<input type="checkbox"/> LM <input type="checkbox"/> BS	-	<input type="checkbox"/> LM <input type="checkbox"/> BS	<input type="checkbox"/> LM <input type="checkbox"/> BS
Payload (kg)/size				___ (___L x ___W)		
Stroke (mm)				± ___°		
Velocity (m/s)				___ rad/s		
Acceleration (m/s ²)				___ rad/s ²		
Movement				<input type="checkbox"/> P to P <input type="checkbox"/> Scan		
PM System						
Repeatability (um)	± ___	± ___	± ___	± ___ arc sec	± ___	± ___
Accuracy (um)	± ___	± ___	± ___	± ___ arc sec	± ___	± ___

6 Project Information *

Surface Finish	<input type="checkbox"/> Standard Surface Finishing <input type="checkbox"/> Black
Electric Control System	<input type="checkbox"/> Yes (Please Fill the Electric Control System Inquiry Form) <input type="checkbox"/> No
Source Inspection	<input type="checkbox"/> Yes (On-site Inspection) <input type="checkbox"/> No
Packaging Method	<input type="checkbox"/> None <input type="checkbox"/> Pallet <input type="checkbox"/> Wooden Box <input type="checkbox"/> HIWIN Standard

Remark:

- Fields marked* are required (P1). For other requirement, please kindly fill P2 – P4
- For special requirement, please kindly fill option 10 to show with sketch with some explanation.

(7 – 10 are optional fields, please fill them if required)

7 Advanced Accuracy Requirements: (If required but not defined, please fill "HIWIN Design")

	Upper Axis	Lower Axis	Vertical Axis	Rotary Axis	Other	Other
Note: For application of laser, optical inspection, exposure...etc. industry, please fill the geometric accuracy information as below:						
Vertical Straightness (um)	±	±	±	±	±	±
Horizontal Straightness (um)	±	±	±	±	±	±
Pitch (arc sec)	±	±	±	±	±	±
Yaw (arc sec)	±	±	±	±	±	±
Servo jitter (um)	±	±	±	±	±	±
Note: For application of low speed scanning, please fill the velocity ripple spec as below:						
Velocity ripple	___% @ ___ mm/s	___% @ ___ mm/s	___% @ ___ mm/s	___% @ ___ mm/s	___% @ ___ mm/s	___% @ ___ mm/s
Note: For application of high-speed point to point, please fill settling time as below:						
Settling time	___% @ ___ um	___% @ ___ um	___% @ ___ um	___% @ ___ um	___% @ ___ um	___% @ ___ um

8 Optional Accessories

	Upper Axis	Lower Axis	Vertical Axis	Rotary Axis	Other	Other
Dust-proof	<input type="checkbox"/> Cover <input type="checkbox"/> Bellow	<input type="checkbox"/> Cover <input type="checkbox"/> Bellow	<input type="checkbox"/> Cover <input type="checkbox"/> Bellow	-	<input type="checkbox"/> Cover <input type="checkbox"/> Bellow	<input type="checkbox"/> Cover <input type="checkbox"/> Bellow
Extension Cable	<input type="checkbox"/> ___M	<input type="checkbox"/> ___M	<input type="checkbox"/> ___M	<input type="checkbox"/> ___M	<input type="checkbox"/> ___M	<input type="checkbox"/> ___M
Cable Chain	<input type="checkbox"/>	<input type="checkbox"/>	<input type="checkbox"/>		<input type="checkbox"/>	<input type="checkbox"/>

Note: For application of clean room, please kindly fill the routing information below. Choose 1 from option A – D

Routing Information	<input type="radio"/> A <input type="checkbox"/> N/A <input type="radio"/> B <input type="checkbox"/> TBA <input type="radio"/> C <input type="checkbox"/> Please Refer Attachment <input type="radio"/> D Spare Room for: <input type="checkbox"/> Wires Ø ___ ___pcs <input type="checkbox"/> Tubes Ø ___* ___pcs <input type="checkbox"/> Other Cables Ø ___* ___pcs
----------------------	---



9 Optional Frame / Structure

	Stage Standing Frame	Machine Housing Material	Door / Panel Material	Damper	Platform Base Material	Other
Type	<input type="checkbox"/> Steel Welded <input type="checkbox"/> Aluminium Extrusion <input type="checkbox"/> Other_____	<input type="checkbox"/> Steel Welded <input type="checkbox"/> Aluminium Extrusion <input type="checkbox"/> Other_____	<input type="checkbox"/> Coated Steel Sheet <input type="checkbox"/> Acrylic Sheet <input type="checkbox"/> Other_____	<input type="checkbox"/> Passive <input type="checkbox"/> Active	<input type="checkbox"/> Granite <input type="checkbox"/> Casting <input type="checkbox"/> Other_____	

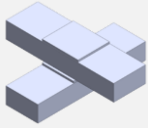
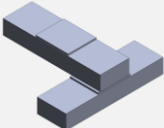
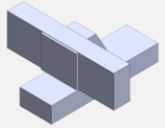
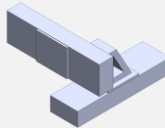
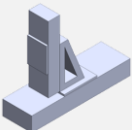

10 Special Requirements

Special Drive Requirement	<input type="checkbox"/> Specified Firmware Version: Ver. _____ <input type="checkbox"/> Fieldbus Communication: _____ <input type="checkbox"/> Position Trigger / Vision on Fly
Special Application	
Special PM System	
Other Requirement	
Reference of existing case	<input type="checkbox"/> Drawing No.: _____ <input type="checkbox"/> O/C: _____

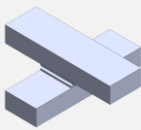
Dual Axes Stage

<input type="checkbox"/> 	<input type="checkbox"/> 	<input type="checkbox"/> 	<input type="checkbox"/> 
<input type="checkbox"/> 	<input type="checkbox"/> 	<input type="checkbox"/> 	<input type="checkbox"/>

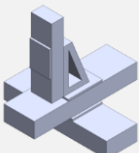
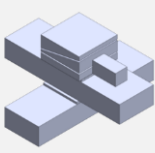
Tri-Axes Stage

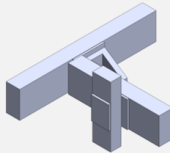
<input type="checkbox"/> 	<input type="checkbox"/> 	<input type="checkbox"/> 	<input type="checkbox"/> 
--	--	---	--

Gantry

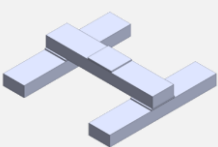
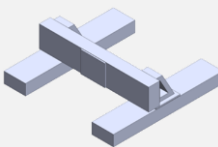
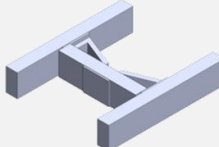
<input type="checkbox"/> 	<input type="checkbox"/> 	<input type="checkbox"/> 	<input type="checkbox"/>
---	---	--	--------------------------

Bridge

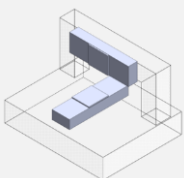
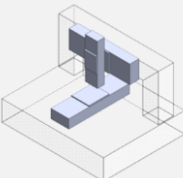
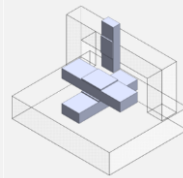
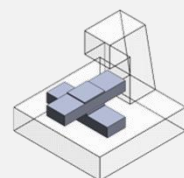
<input type="checkbox"/> 	<input type="checkbox"/> 	<input type="checkbox"/> 	<input type="checkbox"/> 
---	---	--	---

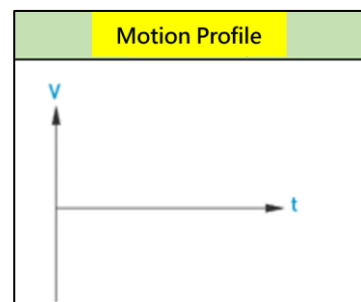
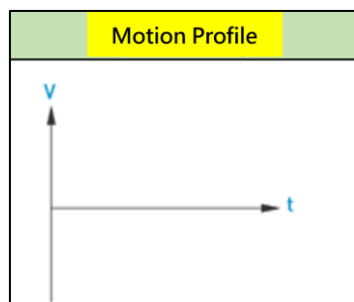
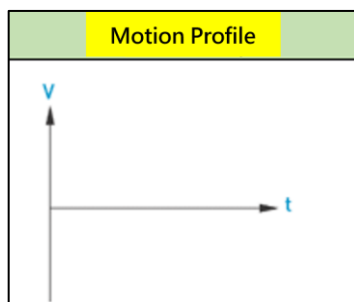

If there is special requirement on motion profile, please select one of above structure or provide sketch image.

Electric Control System:

Fields marked * are required.

*Power System	Input Voltage	<input type="checkbox"/> 110 V <input type="checkbox"/> 220 V (Single phase) <input type="checkbox"/> 220 V (Three-phase) <input type="checkbox"/> Other: _____ V <input type="checkbox"/> HIWIN design	Optional Parts	<input type="checkbox"/> Socket	Input Voltage: _____ V Qty: _____ pc(s)
	Connector Type	<input type="checkbox"/> H Type (Input Current<15 A) <input type="checkbox"/> T Type (Input Current<15 A) <input type="checkbox"/> Bare Wire <input type="checkbox"/> Other:_____		<input type="checkbox"/> I/O Terminal	Input Qty _____ <input type="checkbox"/> NPN <input type="checkbox"/> PNP <input type="checkbox"/> Dry Contact Output Qty _____ <input type="checkbox"/> NPN <input type="checkbox"/> PNP <input type="checkbox"/> Dry Contact Output Current _____ mA
	UPS	<input type="checkbox"/> Yes _____KVA <input type="checkbox"/> No		<input type="checkbox"/> None	
*Control Panel	<input type="checkbox"/> Electric Cabinet (Outside System)	Installation Method: <input type="checkbox"/> Vertical <input type="checkbox"/> Horizontal <input type="checkbox"/> Drawer Type Material and Surface Treatment: <input type="checkbox"/> Stainless Steel <input type="checkbox"/> Aluminium <input type="checkbox"/> Coated <input type="checkbox"/> Non-Coated Size: L: _____ mm W: _____ mm H: _____ mm Distance From System:_____ m	HIWIN Document	<input type="checkbox"/> Spare parts list(.pdf) <input type="checkbox"/> N/A	
			Screen	<input type="checkbox"/> Touchscreen Qty: _____ Size: _____ inches <input type="checkbox"/> Non-touchscreen Qty: _____ Size: _____ inches <input type="checkbox"/> None	
	<input type="checkbox"/> Wiring Panel (Inside System)		*Industrial Specification	<input type="checkbox"/> Required Certification: <input type="checkbox"/> CE <input type="checkbox"/> UL <input type="checkbox"/> SEMI S2 <input type="checkbox"/> Other: _____	
	<input type="checkbox"/> HIWIN Design		*Designated Parts	<input type="checkbox"/> List of Designated Parts(.pdf) (.xls) <input type="checkbox"/> None <input type="checkbox"/> List of Customer-supplied Designated Parts(.pdf) (.xls) <input type="checkbox"/> None	
	<input type="checkbox"/> None				
*Emergency Stop Function	<input type="checkbox"/> Power-off System (Retain Control Power) <input type="checkbox"/> Disable System (Retain Control Power) <input type="checkbox"/> HIWIN Design		Alarm	<input type="checkbox"/> Stack Light <input type="checkbox"/> Buzzer <input type="checkbox"/> Safety Light Curtains <input type="checkbox"/> Other: _____ <input type="checkbox"/> None (multiple choices accepted)	

Special Requirements:

We live motion.



Linear Guideways



Ballscrews



Linear Axes

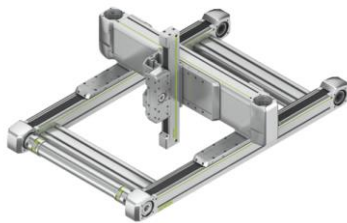

Linear Axis Systems



Torque Motors



Robots



Linear Motors



Rotary Tables



Drives & Servo Motors

Germany

HIWIN GmbH
Brücklesbünd 1
77654 Offenbach
Deutschland
Fon +49 781 93278-0
info@hiwin.de
hiwin.de

Taiwan

Headquarter
HIWIN Technologies Corp.
Nr. 7, Jingke Road
Precision Machinery Park
Taichung 40852
Táiwān
Fon +886 4 2359-4510
business@hiwin.tw
hiwin.tw

Taiwan

Headquarter
HIWIN Mikrosystem Corp.
No. 6, Jingke Central Road
Precision Machinery Park
Taichung 40852
Táiwān
Fon +886 4 2355-0110
business@hiwinmikro.tw
hiwinmikro.tw

France

HIWIN GmbH
4 Impasse Joffre
67202 Wolfisheim
France
Fon +33 3 882884-80
contact@hiwin.fr
hiwin.fr

Poland

HIWIN GmbH Biuro Warszawa
ul. Puławska 405a
02-801 Warszawa
Polska
Fon +48 22 46280-00
info@hiwin.pl
hiwin.pl

Switzerland

HIWIN (Schweiz) GmbH
Eichwiesstraße 20
8645 Jona
Schweiz
Fon +41 55 22500-25
sales@hiwin.ch
hiwin.ch

Italy

HIWIN Srl
Strada Pitagora 4
20861 Brugherio (MB)
Italia
Fon +39 039 28761-68
info@hiwin.it
hiwin.it

Slovakia

HIWIN s.r.o., o.z.z.o.
Mládežnícka 2101
01701 Považská Bystrica
Slovensko
Fon +421 424 4347-77
info@hiwin.sk
hiwin.sk

Czech Republic

HIWIN s.r.o.
Medkova 888/11
62700 Brno
Česká republika
Fon +42 05 48528-238
info@hiwin.cz
hiwin.cz

Denmark

HIWIN GmbH
info@hiwin.dk
hiwin.dk

Netherlands

HIWIN GmbH
info@hiwin.nl
hiwin.nl

Austria

HIWIN GmbH
info@hiwin.at
hiwin.at

Hungary

HIWIN GmbH
info@hiwin.hu
hiwin.hu

Romania

HIWIN GmbH
info@hiwin.ro
hiwin.ro

Slovenia

HIWIN GmbH
info@hiwin.si
hiwin.si

China

HIWIN Corp.
hiwin.cn

Japan

HIWIN Corp.
info@hiwin.co.jp
hiwin.co.jp

USA

HIWIN Corp.
info@hiwin.com
hiwin.us

Korea

HIWIN Corp.
hiwin.kr

Singapore

HIWIN Corp.
hiwin.sg

